

DATASHEET AND OPERATING GUIDE

WXC303 & WXC304

Wxx Series Fan

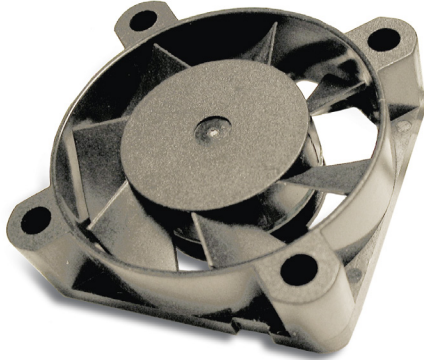

FEATURES & BENEFITS

- Compact size
- 3.5 CFM air flow

INCLUDED IN

- WEV301 Thermal Management Accessory Kit
- WEV302 Thermal Management Accessory Kit

GENERAL DESCRIPTION:

The WXC303 (+5V) and WXC304 (+12V) fan accessories mount directly to the WHS302 Heatsink using two, 1" 4-40 screws. Each fan is 30x30x10mm and produces 3.5 CFM of air flow.

USED WITH

- LDTCxx20 & LDTC2/2 Series Integrated Temperature and Laser Diode Controllers
- WHY5640 Temperature Controller & WHY5690 Evaluation Board
- WLD3343 Series Laser Diode Drivers & WLD3393 Evaluation Board
- WTC3243 Series Temperature Controllers & WTC3293 Evaluation Board
- WTCP5V5A Temperature Controller & WTCPEVAL Evaluation Board

CONTENTS

	PAGE
SAFE OPERATING AREA	2
ASSEMBLY INSTRUCTIONS	2
CERTIFICATION AND WARRANTY	3

ORDERING INFORMATION

PART NO	DESCRIPTION
WXC303	+5 V Fan
WXC304	+12 V Fan

SAFE OPERATING AREA



TO DETERMINE IF THE FAN AND/OR HEATSINK IS REQUIRED IN YOUR APPLICATION, IT IS IMPERATIVE THAT YOU VERIFY THE UNIT WILL BE OPERATING WITHIN THE INTERNAL HEAT DISSIPATION SAFE OPERATING AREA (SOA).

Visit the Wavelength Electronics website for the most accurate, up-to-date, and easy to use SOA calculator.

The SOA calculator for Laser Diode Drivers is at this page: <http://www.teamwavelength.com/support/calculator/soa/soald.php>

The SOA calculator for Temperature Controllers: <http://www.teamwavelength.com/support/calculator/soa/soatc.php>

ASSEMBLY INSTRUCTIONS

Refer to **Figure 1**.

1. Clean All Surfaces where the WTW002 Thermal Washer will contact.
2. Apply the WTW002 Thermal Washer (adhesive side) to the WHS302 Heat Sink surface, aligning the thermal washer holes with the heatsink holes.
3. Secure the WHS302 Heatsink and the WXC303 or the WXC304 Fan (if fan is used) to PDIP14 Package with two screws.

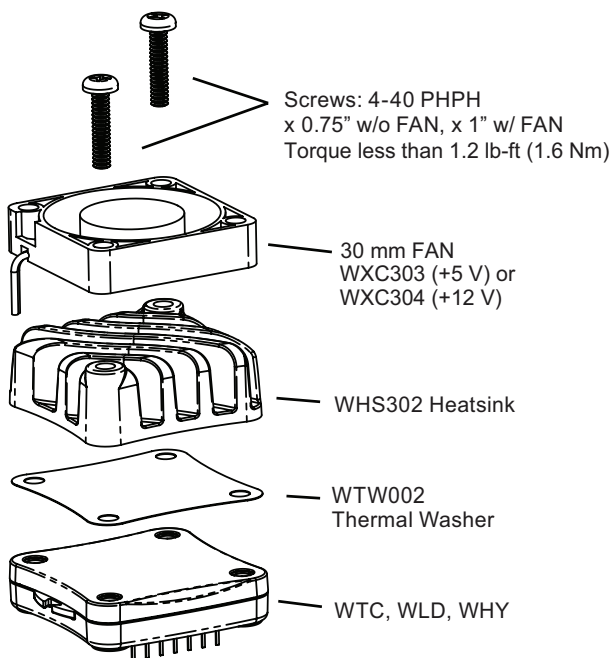
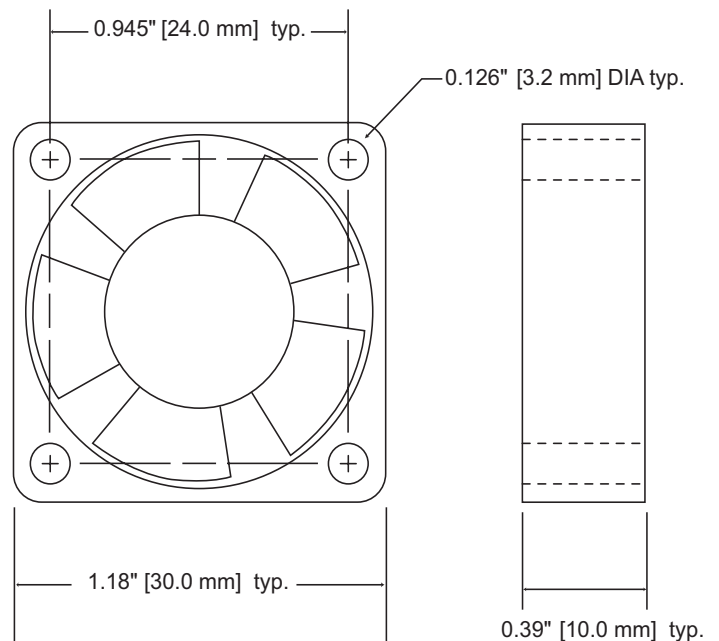

Figure 1. WXC303 or WXC304 Assembled with WHS302 Heatsink and PDIP14 Package

Mechanical specifications for the fan are shown in **Figure 2**.



Dimensions in inches [mm].
 All dimensions $\pm 5\%$ tolerance.
 Appearance of actual fan may vary slightly.
 Refer to WXC303/304 datasheet for additional specifications.

Figure 2. WXC303-304 Fan Dimensions

CERTIFICATION AND WARRANTY

CERTIFICATION

Wavelength Electronics, Inc. (Wavelength) certifies that this product met its published specifications at the time of shipment. Wavelength further certifies that its calibration measurements are traceable to the United States National Institute of Standards and Technology, to the extent allowed by that organization's calibration facilities, and to the calibration facilities of other International Standards Organization members.

WARRANTY

This Wavelength product is warranted against defects in materials and workmanship for a period of one (1) year from date of shipment. During the warranty period, Wavelength will, at its option, either repair or replace products which prove to be defective.

WARRANTY SERVICE

For warranty service or repair, this product must be returned to the factory. An RMA is required for products returned to Wavelength for warranty service. The Buyer shall prepay shipping charges to Wavelength and Wavelength shall pay shipping charges to return the product to the Buyer upon determination of defective materials or workmanship. However, the Buyer shall pay all shipping charges, duties, and taxes for products returned to Wavelength from another country.

LIMITATIONS OF WARRANTY

The warranty shall not apply to defects resulting from improper use or misuse of the product or operation outside published specifications. No other warranty is expressed or implied. Wavelength specifically disclaims the implied warranties of merchantability and fitness for a particular purpose.

EXCLUSIVE REMEDIES

The remedies provided herein are the Buyer's sole and exclusive remedies. Wavelength shall not be liable for any direct, indirect, special, incidental, or consequential damages, whether based on contract, tort, or any other legal theory.

REVERSE ENGINEERING PROHIBITED

Buyer, End-User, or Third-Party Reseller are expressly prohibited from reverse engineering, decompiling, or disassembling this product.

NOTICE

The information contained in this document is subject to change without notice. Wavelength will not be liable for errors contained herein or for incidental or consequential damages in connection with the furnishing, performance, or use of this material. No part of this document may be translated to another language without the prior written consent of Wavelength.

SAFETY

There are no other user-serviceable parts inside this product. Return the product to Wavelength for service and repair to ensure that safety features are maintained.

LIFE SUPPORT POLICY

This important safety information applies to all Wavelength electrical and electronic products and accessories:

As a general policy, Wavelength Electronics, Inc. does not recommend the use of any of its products in life support applications where the failure or malfunction of the Wavelength product can be reasonably expected to cause failure of the life support device or to significantly affect its safety or effectiveness. Wavelength will not knowingly sell its products for use in such applications unless it receives written assurances satisfactory to Wavelength that the risks of injury or damage have been minimized, the customer assumes all such risks, and there is no product liability for Wavelength. Examples of devices considered to be life support devices are neonatal oxygen analyzers, nerve stimulators (for any use), auto-transfusion devices, blood pumps, defibrillators, arrhythmia detectors and alarms, pacemakers, hemodialysis systems, peritoneal dialysis systems, ventilators of all types, and infusion pumps as well as other devices designated as "critical" by the FDA. The above are representative examples only and are not intended to be conclusive or exclusive of any other life support device.

REVISION HISTORY

DOCUMENT NUMBER: WXC303-00400-A80

REV.	DATE	CHANGE
C	October 2013	Release in new format and extended warranty



51 Evergreen Drive
Bozeman, Montana 59715

406-587-4910 (tel)
406-587-4911 (fax)

Sales & Tech Support
sales@teamwavelength.com
techsupport@teamwavelength.com

