

REVISIONS			
REV.	DESCRIPTION	DATE	APPROVED
A	INTRODUCE TO PRR.	11-22-21	GSN
B	RELOCATE MOUNTING HOLES	12-27-22	GSN
C	RELOCATE HOLES TO MATCH CUSTOMER SPEC	1-12-23	GSN

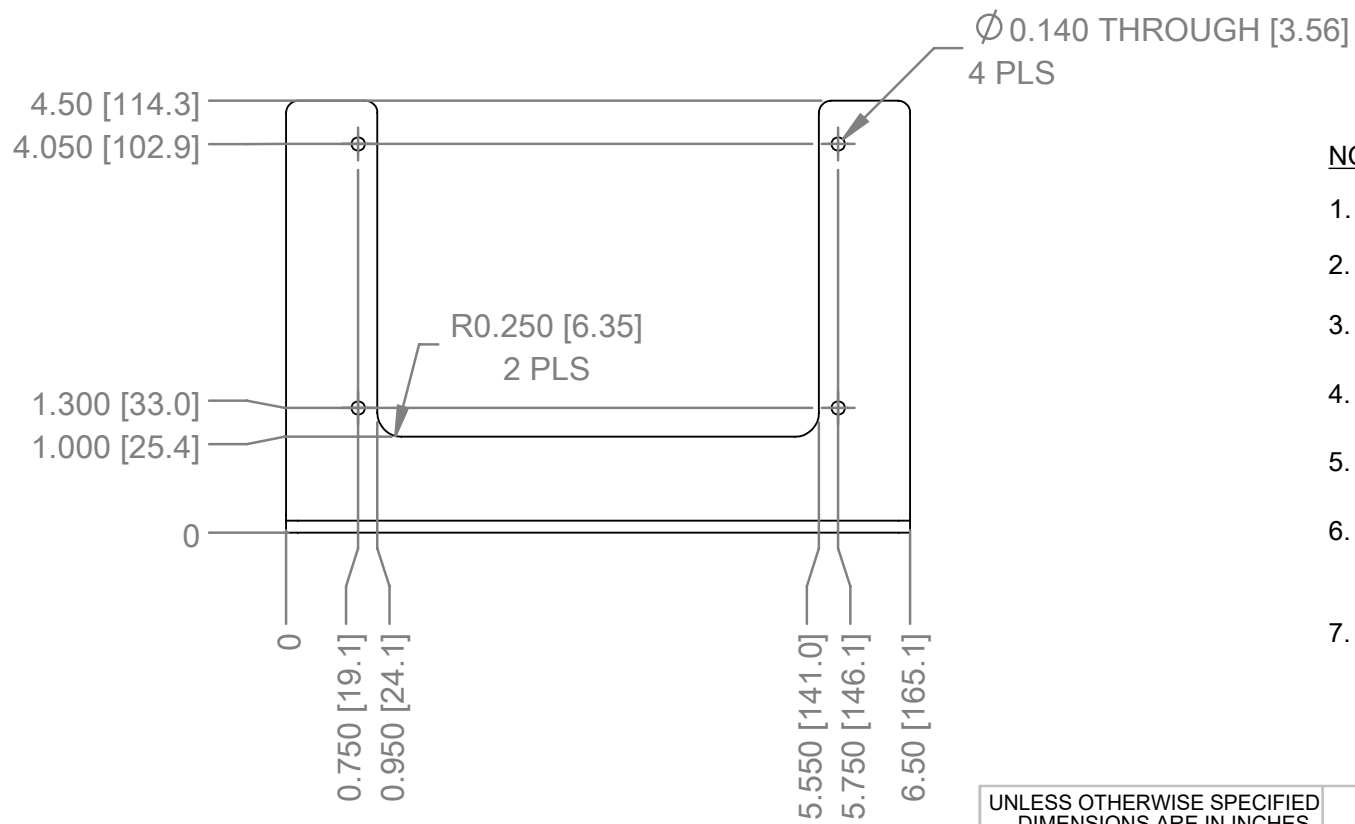
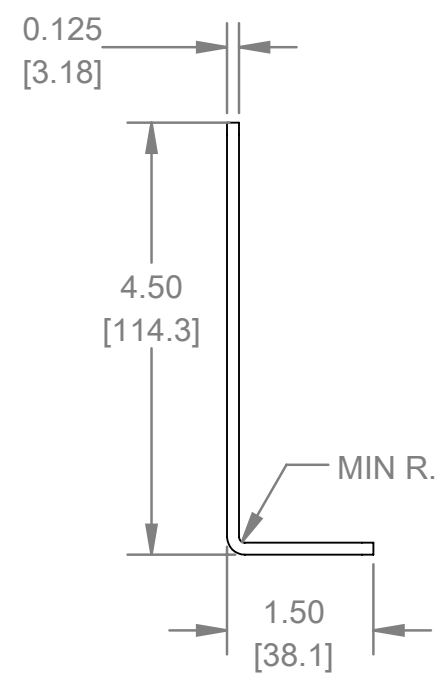
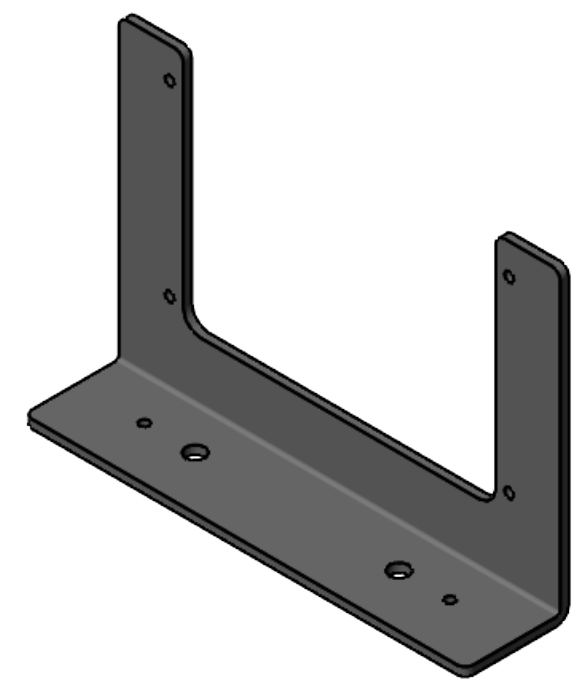
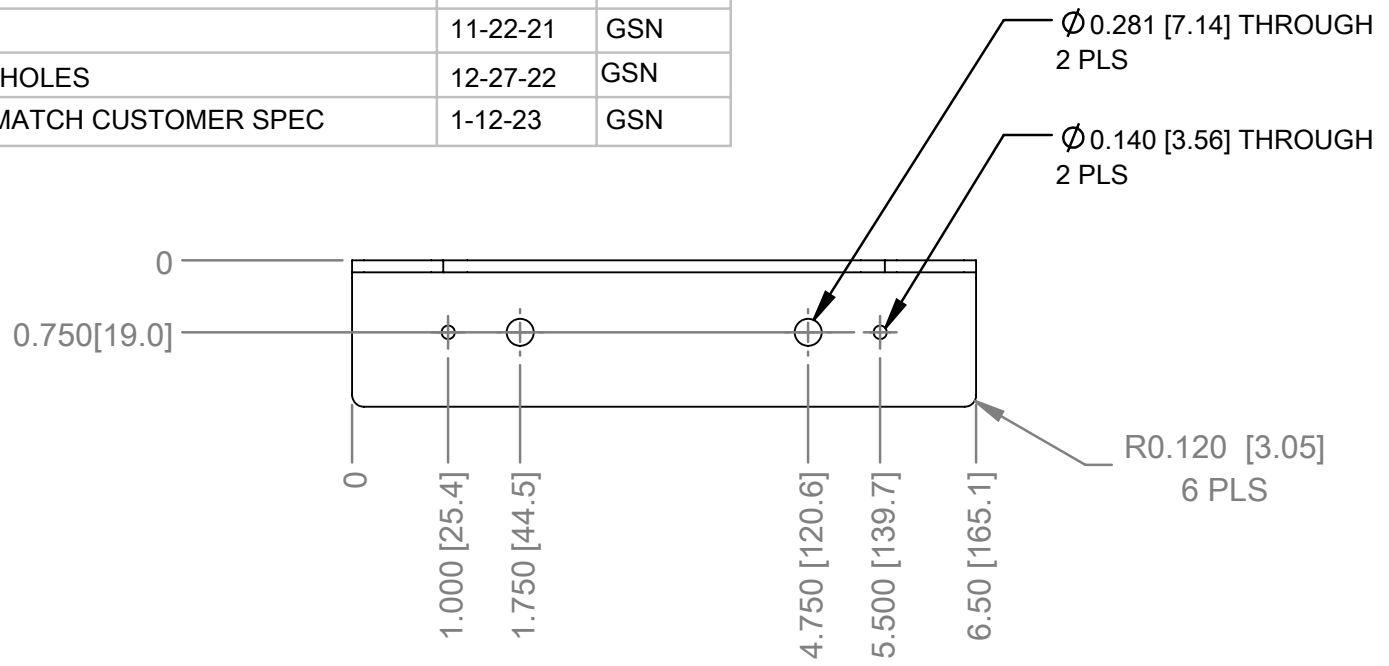

**NOTES:**

- MATERIAL: MAKE FROM 1/8" (.125) THICK 5052-H32 ALUMINUM ALLOY.
- BREAK SHARP EDGES AND REMOVE ALL BURRS.
- DIMENSIONS APPLY AFTER PLATING.
- BLACK ANODIZE PER MIL-A-8625, TYPE II, CLASS 2.
- SURFACE SHALL EXHIBIT NO DEFECTS SUCH AS SCRATCHES, DINGS, MARKS, ETC.
- PACKAGING: PARTS TO BE INDIVIDUALLY PACKAGED TO AVOID DAMAGE DURING SHIPMENT.
- INSPECTION:  
VERIFY OVERALL DIMENSIONS.  
VERIFY SIZE AND PLACEMENT OF HOLES.  
VERIFY ANODIZE FINISH IS CONSISTANT.

UNLESS OTHERWISE SPECIFIED DIMENSIONS ARE IN INCHES

TOLERANCES	
1 PL DECIMALS	± .1
2 PL DECIMALS	± .01
3 PL DECIMALS	± .005
ANGLES ± 1°	
FRACTIONS ± 1/64TH	

THIRD ANGLE PROJECTION



THIS DRAWING AND INFORMATION CONTAINED THEREIN ARE THE PROPERTY OF WAVELENGTH ELECTRONICS, INC. (WEI). BY ACCEPTING THIS INFORMATION, THE BORROWER AGREES THAT IT WILL NOT BE USED FOR ANY PURPOSE OTHER THAN FOR WHICH IT WAS LOANED. IF THE BORROWER OF THIS DOCUMENT HAS NOT SIGNED A CONFIDENTIALITY AGREEMENT WITH WEI, THEN HE/SHE MUST REPORT THIS FACT TO WEI.

APPROVALS		
SIGNATURES		DATE
ORIGINATOR	G. NIEBEL	11-22-21
ENGINEERING		
CHECKED		
APPROVED		
APPROVED		

**WAVELENGTH ELECTRONICS™**  
 Phone: (406) 587-4183  
 Fax: (406)-587-4911  
 51 Evergreen Dr. Suite B  
 Bozeman, MT. 59715

TITLE:		<b>HEATSINK BRACKET</b>	
SIZE	DWG (PRR) NO. :	MOD	
<b>B</b>	<b>31-220008</b>	<b>C</b>	
SCALE: 1:1		SHEET 1 OF 1	

