



WAVELENGTH  
ELECTRONICS

## WTC3293

July, 2010



WTC3243 NOT INCLUDED



### WTC3243 Temperature Controller Evaluation Board

#### GENERAL DESCRIPTION:

Quickly interface an ultrastable WTC3243 Temperature Controller to your thermoelectric or resistive heater load without having to design a printed circuit board. Onboard switches, jumpers, and trimpots make operation simple.

Control temperature using thermistors, 100  $\Omega$  Platinum RTDs, or linear temperature sensors such as the LM335 or the AD590. Adjust temperature using the onboard trimpot or a remote voltage. Other adjustable trimpots configure heat and cool current limits, proportional gain, and integrator time constant. A dipswitch allows the sensor bias current to be optimized for your sensor type.

High power applications can use the onboard fan connections to power a WXC303 or WXC304 (+5 or +12 V) DC fan attached to a WHS302 heatsink.

#### FEATURES:

- Easy to integrate into a system
- Controls temperature using thermistors, 100  $\Omega$  Platinum RTDs, LM335 and AD590 type temperature sensors
- Adjustable Heat and Cool Current Limits
- Adjustable Proportional Gain
- Adjustable Integrator Time Constant
- Remote enable input
- Selectable Sensor Bias (10  $\mu$ A, 100  $\mu$ A, and 1 mA)
- Selectable Sensor Gain (1 or 10) for RTDs
- Enable/Disable Switch and LED indicator
- Setpoint adjustable via onboard potentiometer or remote voltage signal
- Includes 2.5 mm jack input for use with PWRPAK power supplies

#### Ordering Information

WTC3293	2.2 A Evaluation Board for WTC3243
WTC3243	2.2 A Temperature Controller
PWRPAK-5V	5 V Power Supply
PWRPAK-7V	7 V Power Supply
PWRPAK-9V	9 V Power Supply
PWRPAK-12V	12 V Power Supply

Figure 1: Top View

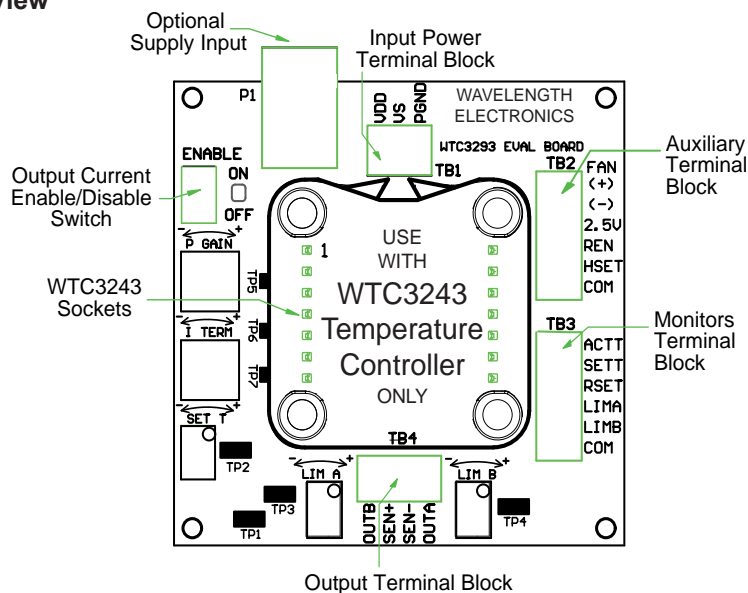
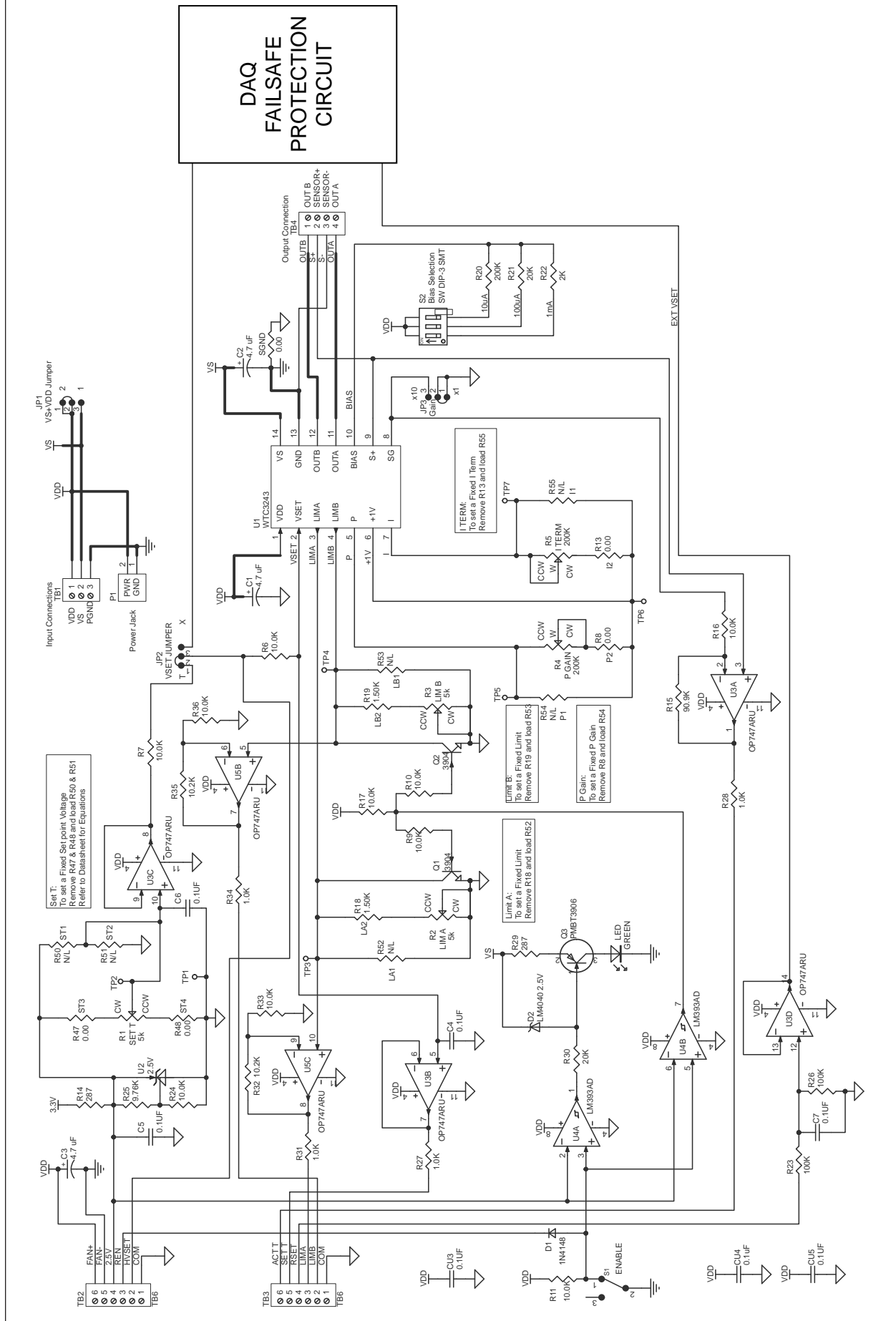

Figure 2: WTC3293 Schematic



ABSOLUTE MAXIMUM RATINGS RATING	SYMBOL	VALUE	UNIT
Supply Voltage (Voltage on Pin 1)	$V_{DD}$	+4.5 to +30	VDC
Supply Voltage (Voltage on Pin 14)	$V_S$	+3 to +30	VDC
Output Current (See SOA Chart)	$I_{OUT}$	2.3	A
Power Dissipation, $T_{AMBIENT} = +25^{\circ}\text{C}$ , w / fan & heatsink (see SOA chart)	$P_{MAX}$	9	W
Operating Temperature, case	$T_{OPR}$	- 40 to + 85	$^{\circ}\text{C}$
Storage Temperature	$T_{STG}$	- 65 to +150	$^{\circ}\text{C}$
Weight		1	ounce

PARAMETER	TEST CONDITIONS	MIN	TYP	MAX	UNITS
Operating Current			$\pm 2.2$		A
Quiescent Current			15		mA
Compliance Voltage, OUTA to OUTB	$I_{OUT} = 100\text{ mA}$ $I_{OUT} = 1.5\text{ A}$ $I_{OUT} = 2.2\text{ A}$		$ V_S - 0.1 $ $ V_S - 0.3 $ $ V_S - 0.6 $		V
Proportional Gain		0		65	A / V <sup>(1)</sup>
Integrator Time Constant		0.53		4.5	seconds <sup>(2)</sup>
Short Term Stability (1 hour) <sup>(3)</sup>	OFF ambient temperature		0.0009		$^{\circ}\text{C}$
Short Term Stability (1 hour) <sup>(3)</sup>	ON ambient temperature		0.002		$^{\circ}\text{C}$
Long Term Stability, (24 hour) <sup>(3)</sup>	OFF ambient temperature		0.002		$^{\circ}\text{C}$
Accuracy: Remote Set T versus Set T Monitor			0.1		%
RSET Input Limits (Remote Setpoint)	Damage threshold: RSET < -0.5 V or RSET > $V_{DD}$	0		6.5	V <sup>(4)</sup>
HSET Input Limits (High Voltage Setpoint)	Damage threshold: HSET < -0.5 V or HSET > $V_{DD}$	0		$V_{DD} - 2.5$	V

## NOTES:

- (1) With added resistor, Proportional Gain range can be increased to 100 A / V.
- (2) Integrator trimpot fully clockwise (CW) = OFF. Trimpot fully counter-clockwise (CCW) = long time constant.
- (3) TSET = 25 $^{\circ}\text{C}$  using 10 k $\Omega$  thermistor.
- (4) RSET low end is affected by the DAQ Failsafe Protection circuit.

## CONFIGURING THE EVALUATION BOARD

### STEP 1: CONFIGURE JUMPERS & SWITCH

#### POWER SELECT JUMPER

The factory default is to separate the  $V_s$  and  $V_{DD}$  power supply inputs.  $V_s$  drives the output stage while  $V_{DD}$  powers the control electronics. You can tie these together instead by moving the Power Select Jumper to the “ $V_s + V_{DD}$ ” position, “1”. Note that when in this position,  $V_s$  on the input terminal block pin will be at the same potential as the  $V_{DD}$  pin.

#### VSET SOURCE JUMPER

The factory default is to use the onboard setpoint trimpot to generate the setpoint voltage (“T” position). To use an external signal through the RSET input, move this jumper to the “X” position. To use the HSET input, completely remove the jumper.

#### SENSOR GAIN JUMPER

If you are using a low resistance thermistor (< 2.5 k $\Omega$ ) or RTD (100  $\Omega$ ), move the jumper to the 10X position to amplify the sensor feedback signal by a factor of ten.

Sensor signal at SEN+ (TB4) should not exceed  $V_{DD} - 2V$ . Minimum recommended signal is 250 mV in order to meet published specifications.

#### SENSOR BIAS SWITCH

Use Table 1 to configure the evaluation board for your temperature sensor type.

Sensor signal at SEN+ (TB4) should not exceed  $V_{DD} - 2V$ . Minimum recommended signal is 250 mV in order to meet published specifications.

Figure 3

#### Power Select Jumper Settings

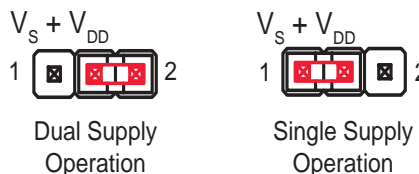

Figure 4

#### VSET Source Jumper Settings

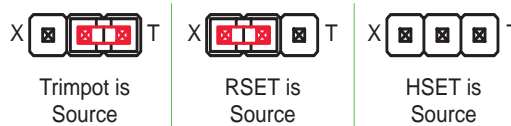

Figure 5

#### Sensor Gain Jumper Settings

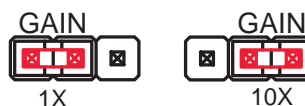
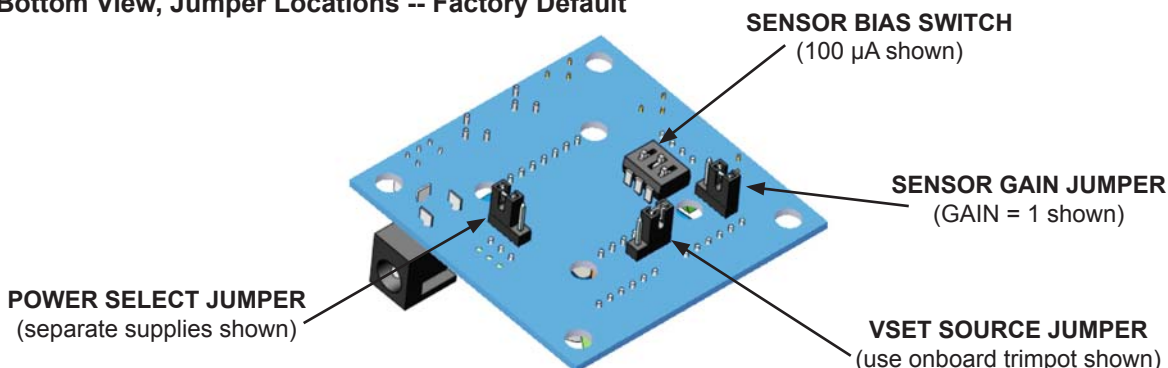

Table 1 - Sensor Dipswitch Configuration

Sensor Type	1 mA	100 $\mu A$	10 $\mu A$
0 to 2.5 k $\Omega$ Thermistor (with GAIN = 10)	Off	On	Off
2.5 k $\Omega$ to 25 k $\Omega$ Thermistor	Off	On	Off
25 k $\Omega$ to 250 k $\Omega$ Thermistor	Off	Off	On
100 $\Omega$ Platinum RTD	On	Off	Off
LM335	On	Off	Off
AD590 (Follow the WTC3243 datasheet for connecting an AD590)	Off	Off	Off

Figure 6

#### Bottom View, Jumper Locations -- Factory Default



**STEP 2: ADJUST THE PROPORTIONAL GAIN AND INTEGRATOR TIME CONSTANT**

NOTE: This step must be done without the WTC3243 installed to allow accurate resistance readings. The Proportional Gain and Integrator Time Constant can be adjusted during operation, but resistance readings will not match these tables with the WTC3243 installed.

Table 2 suggests starting points for Proportional Gain and Integrator Time Constant depending on your sensor type. To optimize control, refer to *Optimizing Thermoelectric Control Systems*, Tech Note TN-TC01 (<http://www.teamwavelength.com/downloads/notes/tn-tc01.pdf#page=1>).

**Table 2 - Proportional Gain and Integrator Time Constant Trimpot Configuration**

Sensor Type	P Gain [A/V]	PGain Trimpot Resistance	I Time Constant [Seconds]	I GAIN Trimpot Resistance
Thermistor	10	11.1 kΩ	3	21.4 kΩ
100 Ω Platinum RTD	50	100 kΩ	1	120 kΩ
LM335	25	33.3 kΩ	2	35.9 kΩ
AD590 (Attach a 10 kΩ resistor across Sensor + and Sensor -)	25	33.3 kΩ	2	35.9 kΩ

**PROPORTIONAL GAIN**

Without the WTC3243 installed, use an ohmmeter to measure resistance between test points 5 and 6 (TP5 & TP6).

Adjust the PGAIN trimpot to the desired resistance.

P is in A / V.

$R_p$  is in ohms.

An online design calculator is available to assist in determining resistance values.

<http://www.teamwavelength.com/support/calculator/wtc/default.php>

**Equation 1**

Calculating  $R_p$  from P

$$R_p = \left( \frac{100,000}{P - 1} \right) [\Omega]$$

**Equation 2**

Calculating P From  $R_p$

$$P = \left( \frac{100}{\frac{100,000}{R_p} + 1} \right) [A / V]$$

**INTEGRATOR TIME CONSTANT**

Without the WTC3243 installed, use an ohmmeter to measure resistance between test points 6 & 7 (TP6 & TP7).

Adjust the I TERM trimpot to the desired resistance.

$I_{TC}$  is in seconds.

$R_i$  is in ohms.

An online design calculator is available to assist in determining resistance values.

<http://www.teamwavelength.com/support/calculator/wtc/default.php>

**Equation 3**

Calculating  $R_i$  from  $I_{TC}$

$$R_i = \left( \frac{100,000}{(1.89) I_{TC} - 1} \right) [\Omega]$$

**Equation 4**

Calculating  $I_{TC}$  from  $R_i$

$$I_{TC} = (0.53) \left( \frac{100,000}{R_i} + 1 \right) [\text{Sec}]$$

## CONFIGURING THE EVALUATION BOARD

### STEP 3: INSTALL THE WTC3243 ON THE EVALUATION BOARD

Match up the notch on the WTC3243 with the silkscreen on the PCB.  
Align the pins with the sockets, ensuring that all pins are lined up.  
Press firmly to seat the WTC3243.

**Make sure that none of the pins were bent during insertion before continuing.**

For additional mechanical stability, install 2 4-40 x 3/8" screws from the bottom of the PCB into the WTC3243 heat spreader. Choose opposite corners that will not interfere with fan mounting.

**Figure 7**  
**Assembling the WTC3243 Thermoelectric Controller to the WTC3293 Evaluation Board**

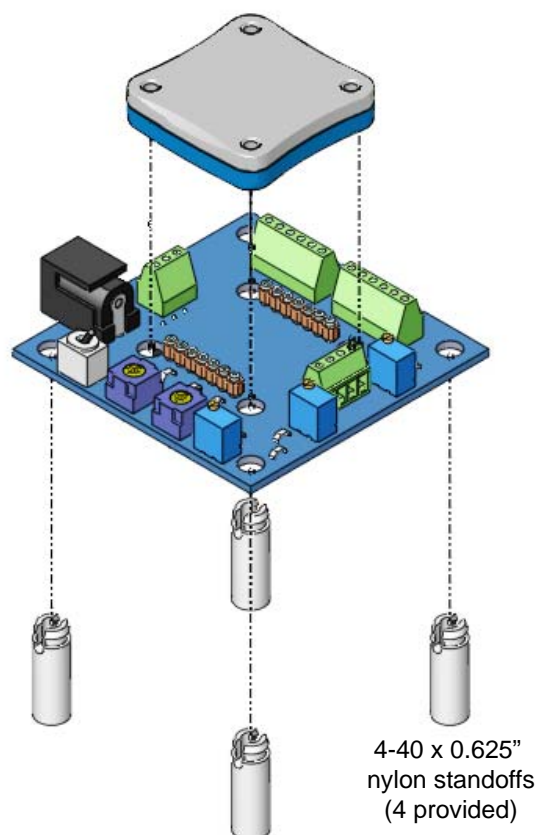

### STEP 4: ATTACHING HEATSINK & FAN (optional for less than +5 V, 500 mA operation)

**HEATSINK REQUIREMENTS.** The WTC3243 is designed to handle currents as high as 2.2 A. Refer to the WTC3243 datasheet or the online SOA calculator (<http://www.teamwavelength.com/support/calculator/soa/soatc.php>) to determine the Safe Operating Area and proper thermal solution for your application. Attach a heatsink (such as WHS302 with thermal washer WTW002) to the WTC3243 when driving currents higher than 500 mA. Attach a fan (such as WXC303 [+5 VDC] or WXC304 [+12 VDC]) to the heatsink for output currents exceeding 1.0 A. If using Wavelength accessories, refer to the WHS302, WTW002, WXC303, and/or the WXC304 datasheets for assembly instructions.

**FAN CONNECTIONS.** Connect the fan leads to the (+) and (-) fan power positions on Terminal Block 2 and secure with a small flat head screwdriver. The fan connects to the  $V_{DD}$  supply, not  $V_S$ , so care must be exercised to ensure that the proper fan is selected, either +5 VDC or +12 VDC, when using dual power supplies.

## CONFIGURING THE EVALUATION BOARD

### STEP 5: ATTACHING THE $V_{DD}$ AND $V_S$ POWER SUPPLIES

The  $V_{DD}$  power supply is used to power the WTC3243 internal control electronics and must be capable of sourcing 100 mA of current. The  $V_S$  power supply is used to power the WTC3243 output stage and must be capable of supplying a current greater than the LIMA and LIMB current limit settings.

For simple operation tie  $V_{DD}$  to  $V_S$  using the Power Select Jumper. See Step 1 for location. Use PGND for the power return. The common (COM) terminal on the WTC3293 is not intended to act as a power connection, but as a low noise ground reference for monitor signals.

A separate  $V_S$  power supply allows the output stage to operate at a voltage lower than the 4.5 volts required by the  $V_{DD}$  supply or up to the +30 V maximum. Select  $V_S$  approximately 2.5 volts above the maximum voltage drop across OUTA and OUTB to reduce the power dissipation in the WTC3243 component and minimize your heatsinking requirements.

The 2.5 mm input power jack is attached to  $V_{DD}$ . You can use the Wavelength PWRPAK power supplies with this jack. Use either the power jack or the power inputs on Terminal Block 1, not both.

### STEP 6: CONFIGURING THE HEAT AND COOL CURRENT LIMITS

The WTC3293 LIMA and LIMB trimpots independently adjust the heat and cool current limits from zero to a full 2.2 A.

With the WTC3243 installed and power to  $V_S$  and  $V_{DD}$  (no load required), set the limits. Rotate LIMA or LIMB trimpot and monitor the respective voltage at LIMA and LIMB on Terminal Block 3 (TB3). Use COM as ground reference.

Use Table 3 to determine polarity of the limits for your sensor and load.

**Table 3 - LIMA and LIMB Current Limit Trimpot Configuration**

Sensor Type	Load Type	LIMA Trimpot	LIMB Trimpot
Thermistor	Thermoelectric	Cool Current Limit	Heat Current Limit
100 $\Omega$ Platinum RTD, LM335, AD590	Thermoelectric	Heat Current Limit	Cool Current Limit
Thermistor	Resistive Heater	Turn Fully CCW	Heat Current Limit
100 $\Omega$ Platinum RTD, LM335, AD590	Resistive Heater	Heat Current Limit	Turn Fully CCW

Use Equation 5 to calculate limit value.

LIMA or LIMB is in V.

$I_{LIM}$  is desired maximum output current in A.

#### Equation 5

Calculating LIMA or LIMB from  $I_{LIM}$

$$LIM = (0.3 * I_{LIM}) + 1$$

Use Table 4 to determine how to connect the WTC3243 outputs (OUTA or OUTB) to your thermoelectric or resistive heater.

**Table 4 - Output Configuration**

Sensor Type	Load Type	Output A	Output B
Thermistor	Thermoelectric	Negative TE Terminal	Positive TE Terminal
100 Ω Platinum RTD, LM335, AD590	Thermoelectric	Positive TE Terminal	Negative TE Terminal
Thermistor	Resistive Heater	<b>Quick Connection:</b> Simply connect the resistive heater to OUTA and OUTB. Adjust the cooling current limit to zero by turning the LIMA trimpot fully CCW. <b>Maximum Voltage Connection:</b> Connect one side of the resistive heater to OUTB and the other side to the voltage source $V_s$ .	
100 Ω Platinum RTD, LM335, AD590	Resistive Heater	<b>Quick Connection:</b> Simply connect the resistive heater to OUTA and OUTB. Adjust the cooling current limit to zero by turning the LIMB trimpot fully CCW. <b>Maximum Voltage Connection:</b> Connect one side of the resistive heater to OUTA and the other side to the voltage source $V_s$ .	

Thermistor and RTD sensors are not polarized, so connect between SEN+ and SEN- on Terminal Block 4. For LM335 and AD490, connect as shown in Figure 8 below.

**Figure 8**  
**Connecting IC Temperature Sensors**

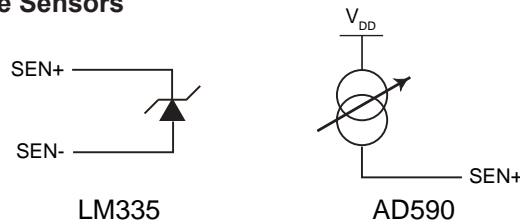

**STEP 8: MONITORING THE TEMPERATURE SETPOINT VOLTAGE AND ACTUAL TEMPERATURE SENSOR VOLTAGE**

Terminal Block 3 (TB3) includes three lines for externally monitoring the WTC3243 temperature setpoint voltage (SET T) and the actual temperature sensor voltage levels (ACT T). Both the SET T and ACT T voltages are measured from the COMMON terminal (COM).

Use Table 5 to convert these monitor voltages to sensor resistance for thermistors and RTDs or temperature for the LM335 and AD590.

**Table 5 - Converting the SET T and ACT T Monitor Voltages**

Sensor Type	Voltage Conversion
Thermistor	$R = \frac{\text{Voltage}^*}{\text{Sensor Bias Current}} [\Omega]$
100 Ω Platinum RTD (where GAIN is 10)	$R = \frac{\text{Voltage}^*}{\text{Sensor Bias Current}} / 10 [\Omega]$
LM335 or AD590	$T = (\text{Voltage}^* - 2.7315) * 100 [C]$

\* Voltage refers to the measurements made from the ACT T or SET T points, in volts. Sensor Bias Current is in amps.

## CONFIGURING THE EVALUATION BOARD

### STEP 9: ADJUSTING THE TEMPERATURE SETPOINT VOLTAGE

The setpoint voltage can be adjusted either by using the evaluation board's onboard SET T trimpot or by connecting a remote voltage source or potentiometer to the RSET or HSET inputs. When under control, the setpoint voltage matches the sensor voltage at the desired temperature.

*To use only the onboard SET T trimpot*, place the VSET SOURCE jumper on the bottom of the WTC3293 evaluation board in the "T" position, and do not connect an external voltage source. The SET T trimpot will allow the setpoint to be adjusted from 0 V to 5 V. Figure 6 shows the jumper location. To get above 4.5 V, increase  $V_{DD}$  to a minimum of 5.5 V.

*To use only an external voltage source for the setpoint*, either place the VSET SOURCE jumper on the bottom of the WTC3293 board to the "X" position and connect the external setpoint voltage source to RSET on TB3, or remove the jumper and connect the external setpoint voltage source to the HSET terminal on TB2. When the VSET SOURCE jumper is in the "X" position or removed, the voltage dialed in using the SET T trimpot on the WTC3293 is ignored. Figure 6 shows the jumper location.

The RSET input is subject to the DAQ Failsafe Protection circuit. If RSET drops below 0.3 V, the setpoint will be overridden and set to 1 V. See the Application Notes section for changing these defaults. RSET is limited to 0-6.5 V.

The HSET remote setpoint input is not subject to the DAQ Failsafe Protection circuit. It is limited to 0 to  $V_{DD} - 2.5$  V.

#### Connecting An External Potentiometer:

**RSET:** Set the VSET SOURCE jumper in the "X" position (subject to DAC Failsafe Protection circuit). Place the potentiometer's CW terminal in the pin marked 2.5 V. Connect the potentiometer's wiper (W) to the pin marked RSET and CCW terminal to the pin marked COM. Do not use less than 2 k $\Omega$  resistance, or the 2.5 V will droop.

**HSET:** Remove the VSET SOURCE jumper (not subject to DAC Failsafe Protection circuit). Place the potentiometer's CW terminal in the pin marked 2.5 V. Connect the potentiometer's wiper (W) to the pin marked HSET and CCW terminal to the pin marked COM. Do not use less than 2 k $\Omega$  resistance, or the 2.5 V will droop.

**Figure 9**  
Example Wiring --  
External Setpoint Adjustment -- RSET

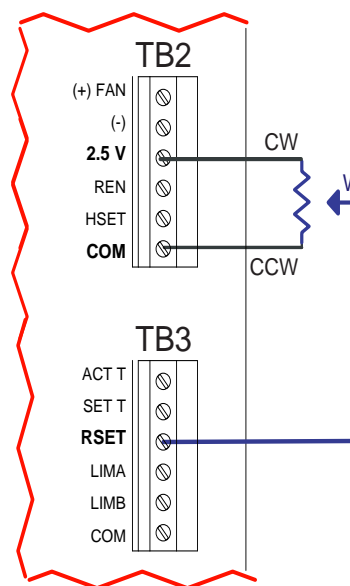

### STEP 10: ENABLING AND DISABLING THE OUTPUT CURRENT

The WTC3243 output current can be enabled and disabled using the onboard toggle switch. The output is enabled when the green ON LED indicator is lit. An external enable signal to REN (TB2) can be used.

0 V =	ENABLED
Floating or >3 V =	DISABLED

The onboard switch overrides the external signal.

If there is no power to  $V_{GS}$ , the enable LED will not light.

## APPLICATION NOTES

To simplify set up or to minimize thermal drift, Wavelength recommends that you eliminate trim pots in circuitry. The following details how to use fixed resistances in place of trim pots. Wavelength can load boards at the factory to your specific requirements. Contact Sales to request a Product Variation.

### Troubleshooting

If the PGAIN or I TERM are turned all the way counterclockwise (CCW), the WTC3293 will not produce current.

If using HSET and the setpoint is 1 V higher than it should be, the VSET SOURCE jumper is not removed.

### DAC Protection -- Change Defaults

If the voltage set by the external input drops below 0.3 V, the failsafe circuit is triggered and the setpoint defaults to 1 V. This prevents overheating of the load if the input signal fails. The 1 V default is designed for 10 kΩ thermistors (1 V = 25 °C). This default is only used with RSET.

To override the failsafe default, remove D1, use the HSET input, or the onboard trim pot.

To change the failsafe trip point, change the voltage divider between D1 & D2. Use the following formula to calculate the appropriate value:

$$V_{\text{TRIP}} = \frac{6.6 D2}{D1 + D2}$$

D1 default is 100 kΩ.

D2 default is 4.99 kΩ.

D1 should not go below 100 kΩ.

To change the default once tripped, change the voltage divider between D3 & D4. Use the following formula to calculate the appropriate value:

$$V_{\text{DEFAULT}} = \frac{6.6 D4}{D3 + D4}$$

D3 default is 49.9 kΩ.

D4 default is 9.76 kΩ.

D3 should not go below 49.9 kΩ.

D1, D2, D3, and D4 are 0805 size resistors.

Figure 10  
DAC Protection Circuit Settings

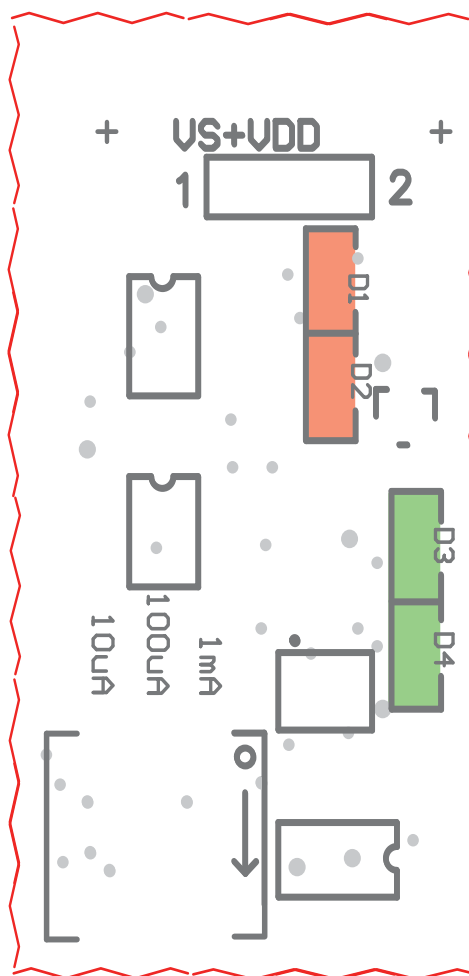

APPLICATION NOTES

**Changing the PGAIN to a Fixed Value**

Once the system is optimized, connect an ohmmeter to TP 5 & 6, without the WTC3243 installed.

Measure the PGAIN trimpot value across pins TP 5 & 6.

Remove P2.

Load P1 with a resistor of the value measured (1206 size).

**Increasing Proportional Gain Range**

Change P2 to a 100 kΩ resistor for

$$P_{MAX} = 75 \text{ A/V.}$$

Remove P2 (infinite resistance) for

$$P_{MAX} = 100 \text{ A/V.}$$

Figure 11 PGAIN Settings

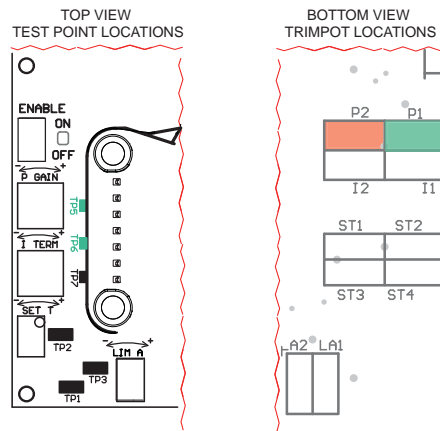

**Changing the I TERM to a Fixed Value**

Once the system is optimized, connect an ohmmeter to TP 6 & 7, without the WTC3243 installed.

Measure the I TERM trimpot value across pins TP 6 & 7.

Remove I2.

Load I1 with a resistor of the value measured (1206 size).

Figure 12 I Term Settings

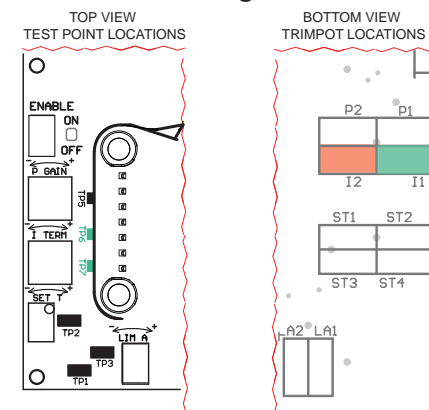

**Changing LIM to a Fixed Value**

Connect an ohmmeter to TP 1 & 3, without the WTC3243 installed.

Measure the LIMA trimpot value across pins TP 1 & 3.

Remove LA2.

Load LA1 with a fixed value to match the trimpot resistance at the proper limit setting (1206 size).

Repeat with LB2 and LB1 and TP 4 & 1, respectively.

Figure 13 LIMA & LIMB Settings

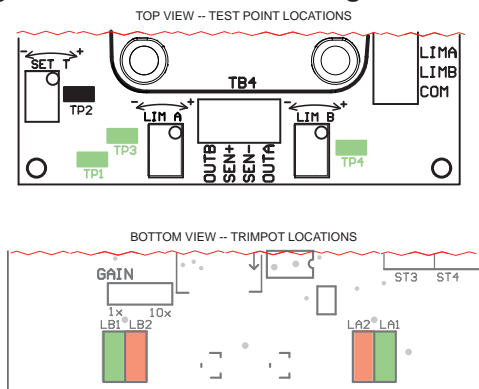

**Changing Onboard Setpoint Trimpot to a Fixed Resistance**

Remove ST3 and ST4. Load ST1 and ST2 such that:

$$\text{Setpoint} = \frac{2.5 * ST2}{ST1 + ST2}$$

ST1 + ST2 must be greater than 5 kΩ.

Setpoint is in volts.

ST1 and ST2 are in ohms (1206 size).

Figure 14 Onboard Setpoint Settings

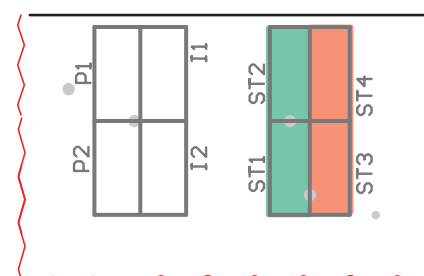

MECHANICAL SPECIFICATIONS

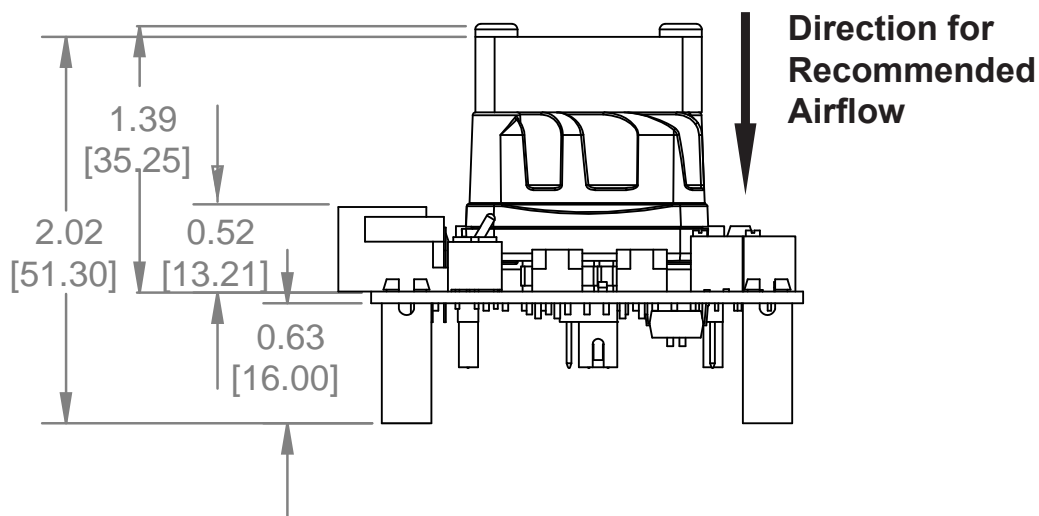
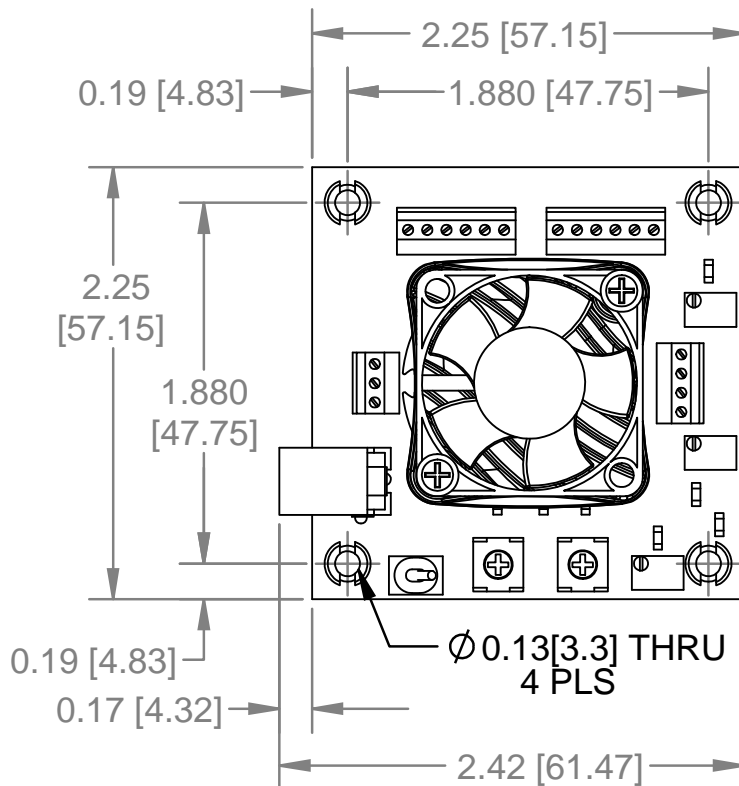

Dimensions are shown in inches [mm]. All tolerances are  $\pm 5\%$ .

**CERTIFICATION:**

Wavelength Electronics, Inc. (Wavelength) certifies that this product met it's published specifications at the time of shipment. Wavelength further certifies that its calibration measurements are traceable to the United States National Institute of Standards and Technology, to the extent allowed by that organization's calibration facilities, and to the calibration facilities of other International Standards Organization members.

**WARRANTY:**

This Wavelength product is warranted against defects in materials and workmanship for a period of 90 days from date of shipment. During the warranty period, Wavelength will, at its option, either repair or replace products which prove to be defective.

**WARRANTY SERVICE:**

For warranty service or repair, this product must be returned to the factory. An RMA is required for products returned to Wavelength for warranty service. The Buyer shall prepay shipping charges to Wavelength and Wavelength shall pay shipping charges to return the product to the Buyer upon determination of defective materials or workmanship. However, the Buyer shall pay all shipping charges, duties, and taxes for products returned to Wavelength from another country.

**LIMITATIONS OF WARRANTY:**

The warranty shall not apply to defects resulting from improper use or misuse of the product or operation outside published specifications.

No other warranty is expressed or implied. Wavelength specifically disclaims the implied warranties of merchantability and fitness for a particular purpose.

**EXCLUSIVE REMEDIES:**

The remedies provided herein are the Buyer's sole and exclusive remedies. Wavelength shall not be liable for any direct, indirect, special, incidental, or consequential damages, whether based on contract, tort, or any other legal theory.

**REVERSE ENGINEERING PROHIBITED:**

Buyer, End-User, or Third-Party Reseller are expressly prohibited from reverse engineering, decompiling, or disassembling this product.

**NOTICE:**

The information contained in this document is subject to change without notice. Wavelength will not be liable for errors contained herein or for incidental or consequential damages in connection with the furnishing, performance, or use of this material. No part of this document may be photocopied, reproduced, or translated to another language without the prior written consent of Wavelength.

**SAFETY:**

There are no user serviceable parts inside this product. Return the product to Wavelength for service and repair to ensure that safety features are maintained.

**LIFE SUPPORT POLICY:**

As a general policy, Wavelength Electronics, Inc. does not recommend the use of any of its products in life support applications where the failure or malfunction of the Wavelength product can be reasonably expected to cause failure of the life support device or to significantly affect its safety or effectiveness. Wavelength will not knowingly sell its products for use in such applications unless it receives written assurances satisfactory to Wavelength that the risks of injury or damage have been minimized, the customer assumes all such risks, and there is no product liability for Wavelength. Examples of devices considered to be life support devices are neonatal oxygen analyzers, nerve stimulators (for any use), auto transfusion devices, blood pumps, defibrillators, arrhythmia detectors and alarms, pacemakers, hemodialysis systems, peritoneal dialysis systems, ventilators of all types, and infusion pumps as well as other devices designated as "critical" by the FDA. The above are representative examples only and are not intended to be conclusive or exclusive of any other life support device.

REVISION HISTORY		
REVISION	DATE	NOTES
REV. E	24-Nov-03	Initial release
REV. F	5-Oct-09	Updated to reflect RoHS compliance
REV. G	23-Jul-10	Added many new features. Revision change to B.



**WAVELENGTH ELECTRONICS, INC.**  
51 Evergreen Drive  
Bozeman, Montana, 59715  
web: [www.teamwavelength.com](http://www.teamwavelength.com)  
phone: (406) 587-4910 Sales/Tech Support  
fax: (406) 587-4911  
e-mail: [sales@teamwavelength.com](mailto:sales@teamwavelength.com)

