



WTC3243

Ultrastable Thermoelectric Controller

GENERAL DESCRIPTION:

The WTC3243 is a powerful, compact analog PI (Proportional, Integral) control loop circuit optimized for use in ultrastable thermoelectric temperature control applications.

The WTC3243 maintains precision temperature regulation using an adjustable sensor bias current and error amplifier circuit that operates directly with thermistors, RTDs, AD590, and LM335 type temperature sensors.

Supply up to 2.2 Amps of heat and cool current to your thermoelectric from a single power supply. Operate resistive heaters by disabling the cooling current output. Adjust temperature at the voltage setpoint input pin. Independently configure the adjustable PI control loop using simple resistors.

An evaluation board is available to quickly integrate the WTC3243 into your system.

The robust and reliable WTC3243 is designed into electro-optical systems, airborne instrumentation, spectroscopic monitors, and medical diagnostic equipment. It is particularly suited to applications where temperature is scanned across ambient.

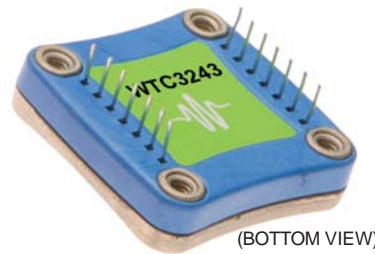

(BOTTOM VIEW)

FEATURES:

- Ultrastable PI Control
- Drive ± 2.2 Amps of TEC or RH Current
- Linear Stability: 0.001°C
- Small Size: 1.3" X 1.26" X 0.313"
- Heat and Cool Current Limits
- Supports Thermistors, RTDs, and IC sensors
- Single Supply Operation: +5 V to +30 V
- Adjustable Sensor Bias Current
- 14-pin DIP PCB Mount
- Monitor Actual Temperature

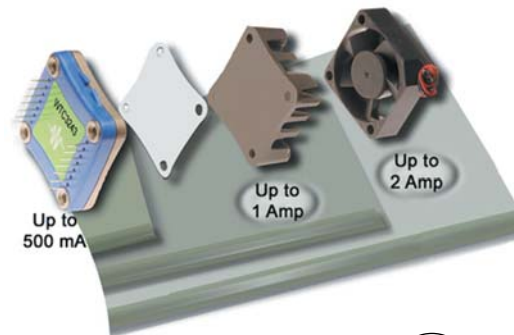

WTC3243 ULTRASTABLE THERMOELECTRIC CONTROLLER

Figure 1
Top View Pin Layout
and Descriptions

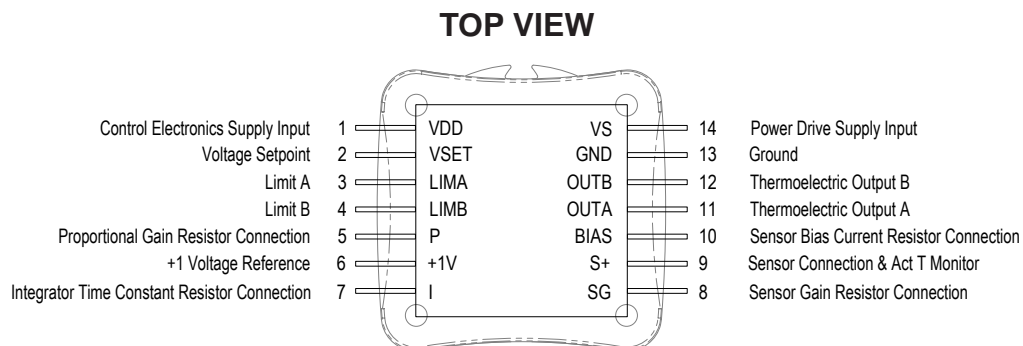

IF YOU ARE UPGRADING FROM THE WHY5640: The position of Pin 1 on the WHY5640 is reversed (or mirrored) relative to the position of Pin 1 on the WTC3243.

Figure 2
Quick Connect
Using Thermistor Temperature Sensors

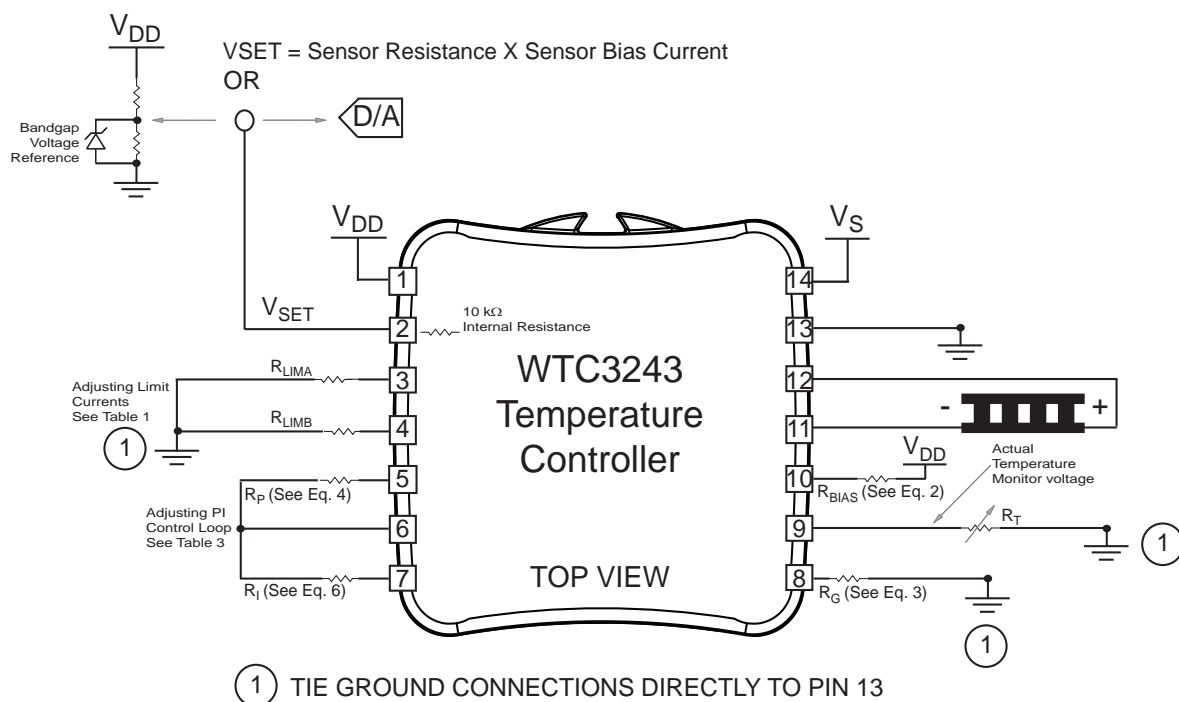

ELECTRICAL AND OPERATING SPECIFICATIONS

PAGE 3

ABSOLUTE MAXIMUM RATINGS RATING	SYMBOL	VALUE	UNIT
Supply Voltage 1 (Voltage on Pin 1 -- can be connected to V_S)	V_{DD}	+4.5 to +30	Volts DC
Supply Voltage 2 (Voltage on Pin 14 -- can be connected to V_{DD})	V_S	+3 to +30	Volts DC
Output Current (See SOA Chart)	I_{OUT}	± 2.2	Amperes
Power Dissipation, $T_{AMBIENT} = +25^\circ\text{C}$ (See SOA Chart) (with fan and heat sink)	P_{MAX}	9	Watts
Operating Temperature, case	T_{OPR}	-40 to +85	$^\circ\text{C}$
Storage Temperature	T_{STG}	-65 to +150	$^\circ\text{C}$
Weight		0.6	ounces

PARAMETER	TEST CONDITIONS	MIN	TYP	MAX	UNITS
TEMPERATURE CONTROL					
Short Term Stability (1 hour) ⁽¹⁾	OFF ambient temperature		0.0009		$^\circ\text{C}$
Short Term Stability (1 hour) ⁽¹⁾	ON ambient temperature		0.002		$^\circ\text{C}$
Long Term Stability, (24 hour) ⁽¹⁾	OFF ambient temperature		0.002		$^\circ\text{C}$
Control Loop		P	PI		
P (Proportional Gain)		1		100	A/V
I (Integrator Time Constant)		0.53		4.5	Sec.
Setpoint vs. Actual Accuracy ⁽¹⁾		0.1	2 <1% (Rev A)	4	mV
OUTPUT					
Current, peak, see SOA Chart		± 2.0		± 2.2	Amps
Compliance Voltage, Pin 11 to Pin 12	Full Temp. Range, $I_{OUT} = 100\text{ mA}$		$ V_S - 0.1 $		Volts
Compliance Voltage, Pin 11 to Pin 12	Full Temp. Range, $I_{OUT} = 1\text{ Amp}$		$ V_S - 0.3 $		Volts
Compliance Voltage, Pin 11 to Pin 12	Full Temp. Range, $I_{OUT} = 1.5\text{ Amps}$		$ V_S - 0.3 $		Volts
Compliance Voltage, Pin 11 to Pin 12	Full Temp. Range, $I_{OUT} = 2.0\text{ Amps}$		$ V_S - 0.6 $		Volts
Compliance Voltage, Resistive Heater	Full Temp. Range, $I_{OUT} = 2.2\text{ Amps}$		$ V_S - 0.6 $		Volts
POWER SUPPLY					
Voltage, VDD		4.5		30	Volts
Current, VDD supply, quiescent			8		mA
Voltage, Vs		3		30	Volts
Current, Vs supply, quiescent			8		mA

NOTES:

⁽¹⁾ TSET = 25 $^\circ\text{C}$ using 10 k Ω thermistor

ELECTRICAL AND OPERATING SPECIFICATIONS

WTC3243

PARAMETER	TEST CONDITIONS	MIN	TYP	MAX	UNITS
INPUT					
Offset Voltage, initial	Pins 2 and 9		1	2	mV
Bias Current	Pins 2 and 9, T _{AMBIENT} = 25°C		20	50	nA
Offset Current	Pins 2 and 9, T _{AMBIENT} = 25°C		2	10	nA
Common Mode Range	Pins 2 and 9, Full Temp. Range	0		VDD-2 ¹	V
Common Mode Rejection	Full Temperature Range	60	85		dB
Power Supply Rejection	Full Temperature Range	60	80		dB
Input Impedence			500		kΩ
Input voltage range		GND		VDD-2 ¹	Volts
VSET (Pin 2) Damage Threshold		> V _{DD} + 0.5 or < -0.5			Volts
THERMAL					
Heatspreader Temperature Rise	T _{AMBIENT} = 25°C	28	30	33	°C/W
Heatspreader Temperature Rise	With WHS302 Heatsink, WTW002 Thermal Washer	18	21.5	25	°C/W
Heatspreader Temperature Rise	With WHS302 Heatsink, WTW002 Thermal Washer, and 3.5 CFM Fan	3.1	3.4	3.9	°C/W

¹The bias source has a compliance up to VDD - 2.0 V. In normal operation this limits the sensor voltage range from 0.0V to VDD - 2.0V. While voltages up to +/- 5V outside this range on the Vset pin will not damage the unit, it will not provide proper control under these conditions.

PIN DESCRIPTIONS

PIN NO.	PIN	NAME	FUNCTION
1	VDD	Control Electronics Power Supply Input	Connect a +4.5V to +30V power supply to Pin 1 (VDD) and Pin 13 (GND). NOTE: can be connected to V_S .
2	VSET	Voltage Setpoint [Setpoint voltage equations are sensor dependent & noted on operating diagrams]	Connect a voltage source between Pin 2 (VSET) and Pin 13 (GND) to control the temperature setting.
3	LIMA	Limit A	A resistor connected between Pin 3 (LIMA) and Pin 13 (GND) limits the output current drawn off the Pin 14 (VS) supply input to the Pin 11 (OUTA).
4	LIMB	Limit B	A resistor connected between Pin 4 (LIMB) and Pin 13 (GND) limits the output current drawn off the Pin 14 (VS) supply input to the Pin 12 (OUTB).
5	P	Proportional Gain Resistor Connection	Connect a resistor between Pin 5 (P) and Pin 6 (+1V) to configure the Proportional Gain setting.
6	+1V	+1 Volt	+1 Volt Reference
7	I	Integrator Time Constant Resistor Connection	Connect a resistor between Pin 7 (I) and Pin 6 (+1V) to configure the Integrator Time Constant setting.
8	SG	Sensor Gain Resistor Connection	Connect a resistor between Pin 8 (SG) and Pin 13 (GND) to adjust the Sensor Gain setting.
9	S+	Sensor Connection	Connect resistive and LM335 type temperature sensors across Pin 9 (S+) and Pin 13 (GND). Connect a 10 k Ω resistor across Pin 9 (S+) and Pin 13 (GND) when using AD590 type temperature sensors. The negative terminal of the AD590 sensor connects to Pin 9 (S+) and the positive terminal to Pin 1 (VDD). AD590 operation requires that VDD be +8 Volts or greater for proper operation.
10	BIAS	Sensor Bias Current Resistor Connection	Connect a resistor between Pin 10 (BIAS) and Pin 1 (VDD) to configure the sensor bias current.

IF YOU ARE UPGRADING FROM THE WHY5640: The position of Pin 1 on the WHY5640 is reversed (or mirrored) relative to the position of Pin 1 on the WTC3243.

PIN NO.	PIN	NAME	FUNCTION
11	OUTA	Thermoelectric Output A	Connect Pin 11 (OUTA) to the negative terminal on your thermoelectric when controlling temperature with Negative Temperature Coefficient thermistors. With NTC sensors the TEC current will flow from OUTA to OUTB when heating (opposite polarity for PTC sensors). Connect Pin 11 (OUTA) to the positive thermoelectric terminal when using Positive Temperature Coefficient RTDs, LM335 type, and AD590 type temperature sensors.
12	OUTB	Thermoelectric Output B	Connect Pin 12 (OUTB) to the positive terminal on your thermoelectric when controlling temperature with Negative Temperature Coefficient thermistors. With NTC sensors the TEC current will flow from OUTB to OUTA when cooling (opposite polarity for PTC sensors). Connect Pin 12 (OUTB) to the negative thermoelectric terminal when using Positive Temperature Coefficient RTDs, LM335 type, and AD590 type temperature sensors.
13	GND	Ground	Connect the power supply ground connections to Pin 13 (GND). All ground connections to this pin should be wired separately.
14	VS	Power Drive Supply Input	Provides power to the WTC3243 H-Bridge power stage. Supply range input for this pin is +3 to +30 Volts DC. The maximum current drain on this terminal should not exceed 2.2 Amps. CAUTION: Care should be taken to observe the maximum power dissipation limits before applying power to the device. NOTE: can be connected to V_{DD} .

IF YOU ARE UPGRADING FROM THE WHY5640: The position of Pin 1 on the WHY5640 is reversed (or mirrored) relative to the position of Pin 1 on the WTC3243.

Caution:

Do not exceed the Safe Operating Area (SOA). Exceeding the SOA voids the warranty.

An online tool is available for calculating Safe Operating Area at:

<http://www.teamwavelength.com/support/calculator/soa/soatc.php>.

To determine if the operating parameters fall within the SOA of the device, the maximum voltage drop across the controller and the maximum current must be plotted on the SOA curves.

These values are used for the example SOA determination:

$V_s = 12$ volts

$V_{load} = 5$ volts

$I_{load} = 1$ amp

} These values are determined from the specifications of the TEC or resistive heater

Follow these steps:

1. Determine the maximum voltage drop across the controller, $V_s - V_{load}$, and mark on the X axis. (12 volts - 5 volts = 7 volts, Point A)
2. Determine the maximum current, I_{load} , through the controller and mark on the Y axis: (1 amp, Point B)
3. Draw a horizontal line through Point B across the chart. (Line BB)
4. Draw a vertical line from Point A to the maximum current line indicated by Line BB.
5. Mark V_s on the X axis. (Point C)
6. Draw the Load Line from where the vertical line from point A intersects Line BB down to Point C.

Refer to the chart shown below and note that the Load Line is in the Unsafe Operating Areas for use with no heatsink (1) or the heatsink alone (2), but is outside of the Unsafe Operating Area for use with heatsink and Fan (3).

WTC3243 Safe Operating Area

25°C Ambient
75°C Case Maximum

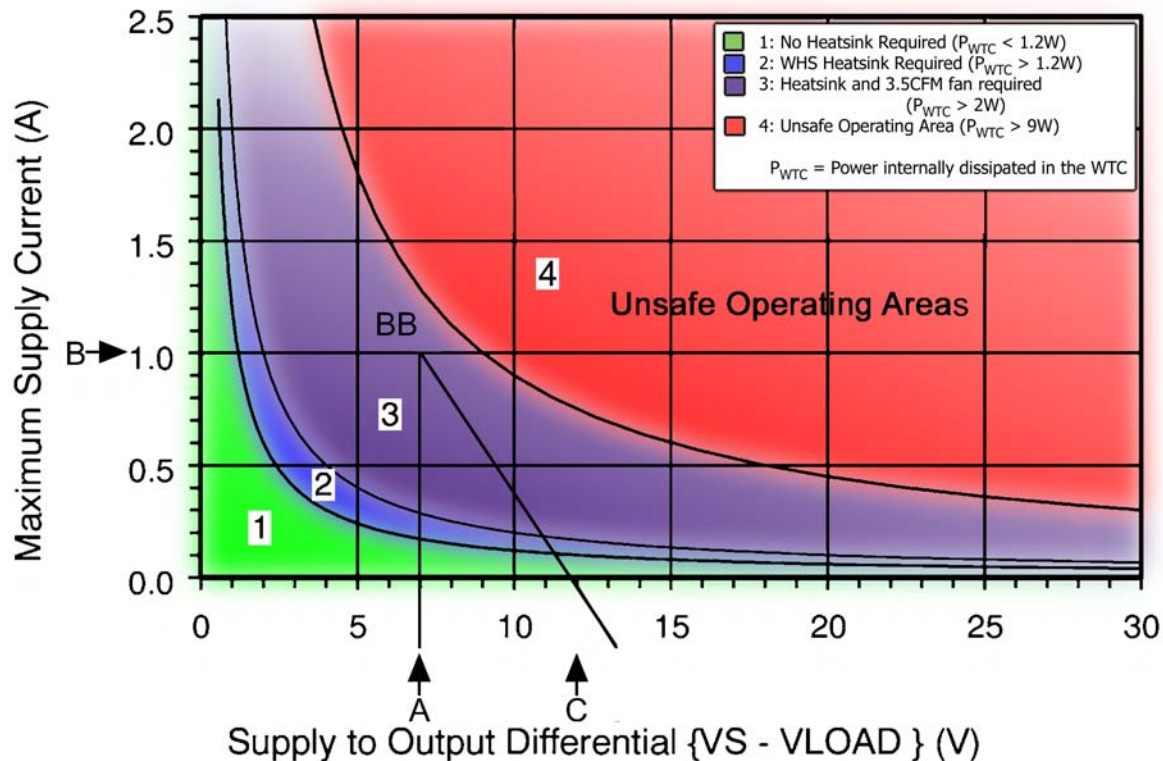

1. CONFIGURING HEATING AND COOLING CURRENT LIMITS

Refer to Table 1 to select appropriate resistor values for R_A and R_B .

Setting Current Limits Independently Using Trimpots

The 5 k Ω trimpots shown in Figure 4 adjust the maximum output currents from 0 to 2.2 Amps.

Heat and Cool Current Limits

APPROXIMATE VALUE OF CURRENT LIMIT RESISTOR R_c vs MAXIMUM OUTPUT CURRENT

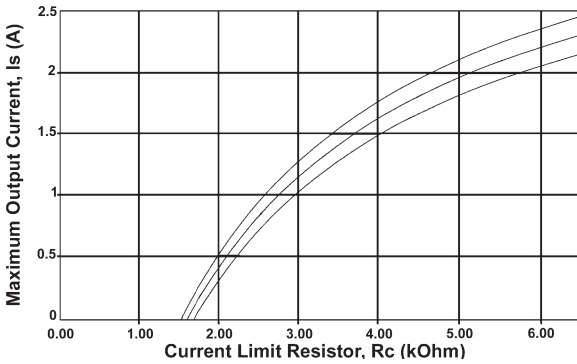

Table 1
Current Limit Set Resistor vs Maximum Output Current

Maximum Output Current (Amps)	Maximum Output Current ($k\Omega$) R_A, R_B
0.0	1.58
0.1	1.66
0.2	1.74
0.3	1.83
0.4	1.92
0.5	2.01
0.6	2.11
0.7	2.22
0.8	2.33
0.9	2.45
1.0	2.58
1.1	2.71
1.2	2.86
1.3	3.01
1.4	3.18
1.5	3.36
1.6	3.55
1.7	3.76
1.8	3.98
1.9	4.23
2.0	4.50
2.1	4.79
2.2	5.11

Figure 3
Fixed Heat and Cool Current Limits

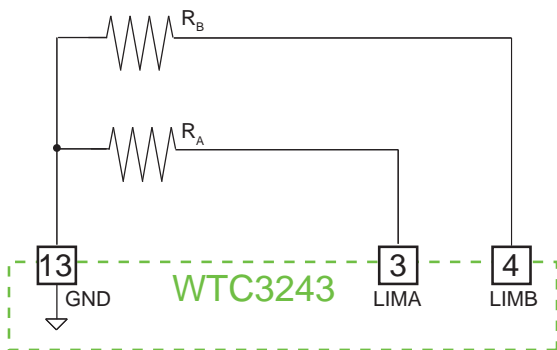
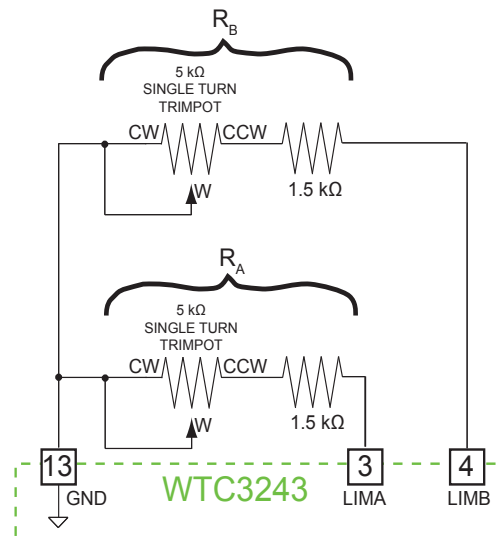

Figure 4
Independently Adjustable Heat and Cool Current Limits



OPERATION

2. RESISTIVE HEATER TEMPERATURE CONTROL

The WTC3243 can operate resistive heaters by disabling the cooling output current. When using Resistive Heaters with NTC thermistors, connect Pin 3 (LIMA) to Pin 13 (GND) with a 1.5 kΩ resistor.

Connect Pin 4 (LIMB) to Pin 13 (GND) with a 1.5 kΩ resistor when using RTDs, LM335 type, and AD590 type temperature sensors with a resistive heater.

3. DISABLING THE OUTPUT CURRENT

The output current can be enabled and disabled, as shown in Figure 5, using a DPST (Double Pole–Single Throw) switch.

4. DETERMINING I_{BIAS}

Connect a resistor R_{BIAS} between Pin 10 (BIAS) and Pin 1 (VDD) to adjust the sensor bias current. The resistance of your sensor in conjunction with the sensor bias current must produce a setpoint voltage between 0.25 V and (V_{DD} - 2 V) in order to be used in the control loop. Equation 1 shows the relationship.

5. ADJUSTING THE SENSOR BIAS CURRENT AND SENSOR GAIN FOR RESISTIVE TEMPERATURE SENSORS

Table 2 lists the suggested resistor values for R_{BIAS} versus the range of resistances of the resistive temperature sensor. Equation 2 demonstrates how to calculate a value of R_{BIAS} given a desired sensor bias current, I_{BIAS}.

When using RTDs, signal can be very low. The sensor signal applied to Pin 9 (S+) can be amplified up to a factor of 10 by inserting a resistor, R_G, between Pin 8 (SG) and Pin 13 (GND). Connect Pin 8 (SG) directly to Pin 13 (GND) for a sensor gain of 10.09. The lower the value of R_G, the more gain applied to the sensor signal.

Equation 3 demonstrates how to calculate a value for R_G given a desired sensor gain.

Table 2 lists the suggested resistor values for R_G versus the range of resistances of the resistive temperature sensor.

Figure 5
Disabling the Output Current

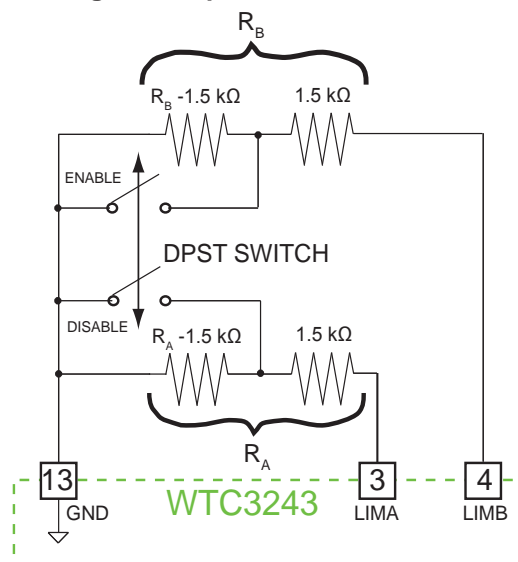

Equation 1

Calculating I_{BIAS}

$$I_{BIAS} = \frac{V_{SET}}{\text{Sensor Resistance}}$$

Equation 2

Calculating R_{BIAS}

$$R_{BIAS} = \frac{2}{I_{BIAS}} [\Omega]$$

Equation 3

Calculating R_G

$$R_G = \left(\frac{90,900}{(G_{sensor} - 1)} - 10,000 \right) [\Omega]$$

Table 2

Recommended Bias Current based on sensor type and resistance

Sensor Type	R _{BIAS}	I _{BIAS}	R _G	Sensor Gain
2.252 kΩ Thermistor	2 kΩ	1 mA	Open	1
5 kΩ Thermistor	10 kΩ	200 μA	Open	1
10 kΩ Thermistor	20 kΩ	100 μA	Open	1
20 kΩ Thermistor	40 kΩ	50 μA	Open	1
50 kΩ Thermistor	100 kΩ	20 μA	Open	1
100 kΩ Thermistor	200 kΩ	10 μA	Open	1
500 kΩ Thermistor	1 MΩ	2 μA	Open	1
100 Ω Platinum RTD	2 kΩ	1 mA	Short or 100 Ω *	10
1 kΩ Platinum RTD	2 kΩ	1 mA	Open	1
LM335	2 kΩ	1 mA	Open	1
		R _{BIAS}		
AD590	Open	10 kΩ	Open	1

* Sensor gain with 100 Ω is exactly 10. Sensor gain shorted is 10.09

OPERATION

6. ADJUSTING THE CONTROL LOOP PROPORTIONAL GAIN

The control loop proportional gain can be adjusted by inserting a resistor, R_p , between Pin 5 (P) and Pin 6 (+1V) to set P from 1 to 100.

Equation 4 demonstrates how to calculate a value for R_p given a desired proportional gain.

Equation 5 demonstrates how to calculate the Proportional gain, P, given a value for R_p .

Table 3 lists the suggested resistor values for R_p versus sensor type and the ability of the thermal load to change temperature rapidly.

7. ADJUSTING THE CONTROL LOOP INTEGRATOR TIME CONSTANT

The control loop integrator time constant can be adjusted by inserting a resistor, R_i , between Pin 6 (+1V) and Pin 7 (I) to set I_{TC} from 0.53 to 4.5 seconds.

Equation 6 demonstrates how to calculate a value for R_i given a desired integrator time constant. The integrator time constant, I_{TC} , is measured in seconds.

Equation 7 demonstrates how to calculate the integrator time constant, I_{TC} , given a value for R_i .

Table 4 lists the suggested resistor values for R_i versus sensor type and the ability of the thermal load to change temperature rapidly.

Overshoot with Small Loads

When using the WTC with small, fast loads, the unit has a tendency to overshoot by up to 10°C. This problem is caused by overcompensation by the integrator and can be solved by taking the integrator term out of the system. This can be done by placing a shorting jumper between Pin 6 (+1V) and Pin 7 (I).

Equation 4

Calculating R_p from P

$$R_p = \left[\frac{100,000}{\frac{100}{P} - 1} \right] [\Omega]$$

Equation 5

Calculating P From R_p

$$P = \left[\frac{100}{\frac{100,000}{R_p} + 1} \right] [\text{Amps / Volts}]$$

Equation 6

Calculating R_i from I_{TC}

$$R_i = \left[\frac{100,000}{(1.89) I_{TC} - 1} \right] [\Omega]$$

Equation 7

Calculating I_{TC} from R_i

$$I_{TC} = (0.53) \left[\frac{100,000}{R_i} + 1 \right] [\text{Seconds}]$$

Table 3

Proportional Gain Resistor R_p vs Sensor Type and Thermal Load Speed

Proportional Gain Resistor, R_p	Proportional Gain, [Amps/Volt]	Sensor Type/ Thermal Load Speed
4.99 k Ω	5	Thermistor/Fast
24.9 k Ω	20	Thermistor/Slow
100 k Ω	50	RTD/Fast
Open	100	RTD/Slow
24.9 k Ω	20	AD590 or LM335/ Fast
100 k Ω	50	AD590 or LM335/ Slow

Table 4

Integrator Time Constant vs Sensor Type and Thermal Load Speed

Integrator Resistor, R_i	Integrator Time Constant, [Seconds]	Sensor Type/ Thermal Load Speed
21.4 k Ω	3	Thermistor/Fast
13.3 k Ω	4.5	Thermistor/Slow
Open	0.53	RTD/Fast
112 k Ω	1	RTD/Slow
112 k Ω	1	AD590 or LM335/ Fast
13.3 k Ω	4.5	AD590 or LM335/ Slow

8. OPERATING WITH THERMISTOR TEMPERATURE SENSORS

The diagrams on this page demonstrates how to configure the WTC3243 for operation with a thermistor temperature sensor. An online calculation utility to determine resistances is available at: <http://www.teamwavelength.com/support/calculator/wtc/default.php>.

THERMISTOR / THERMOELECTRIC OPERATION -- TOP VIEW

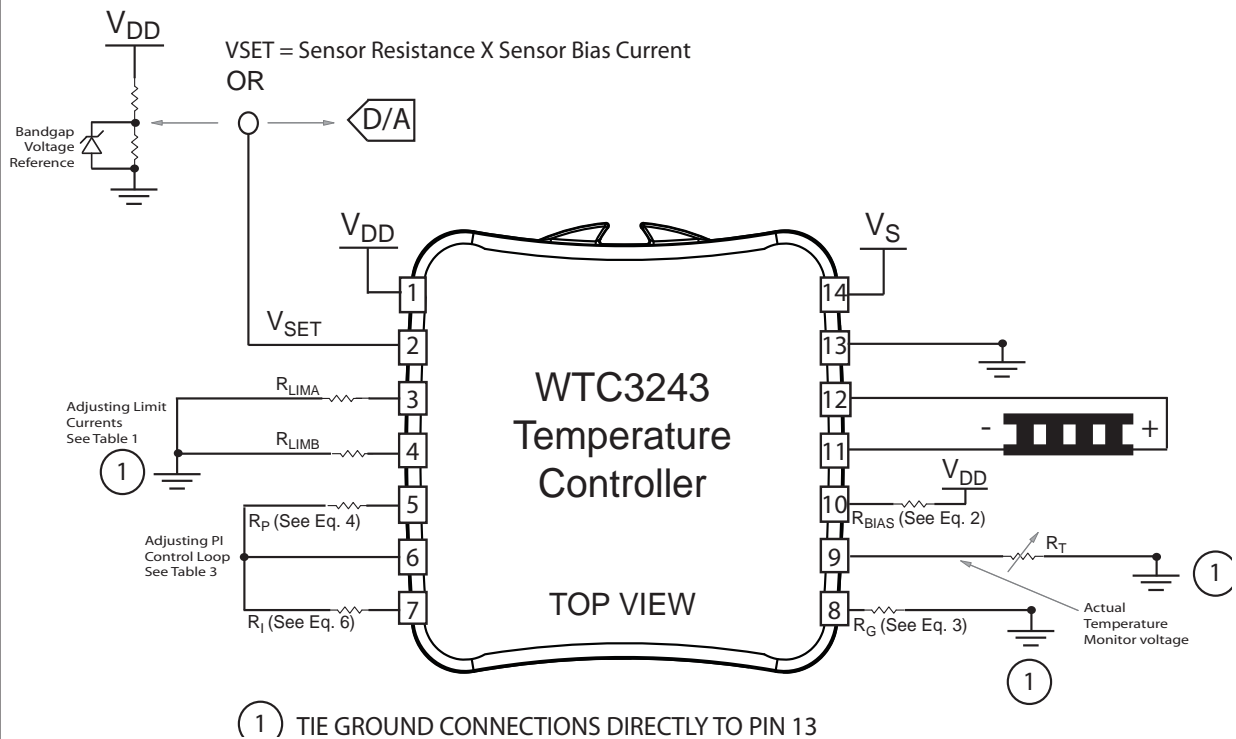

THERMISTOR / RESISTIVE HEATER OPERATION -- TOP VIEW

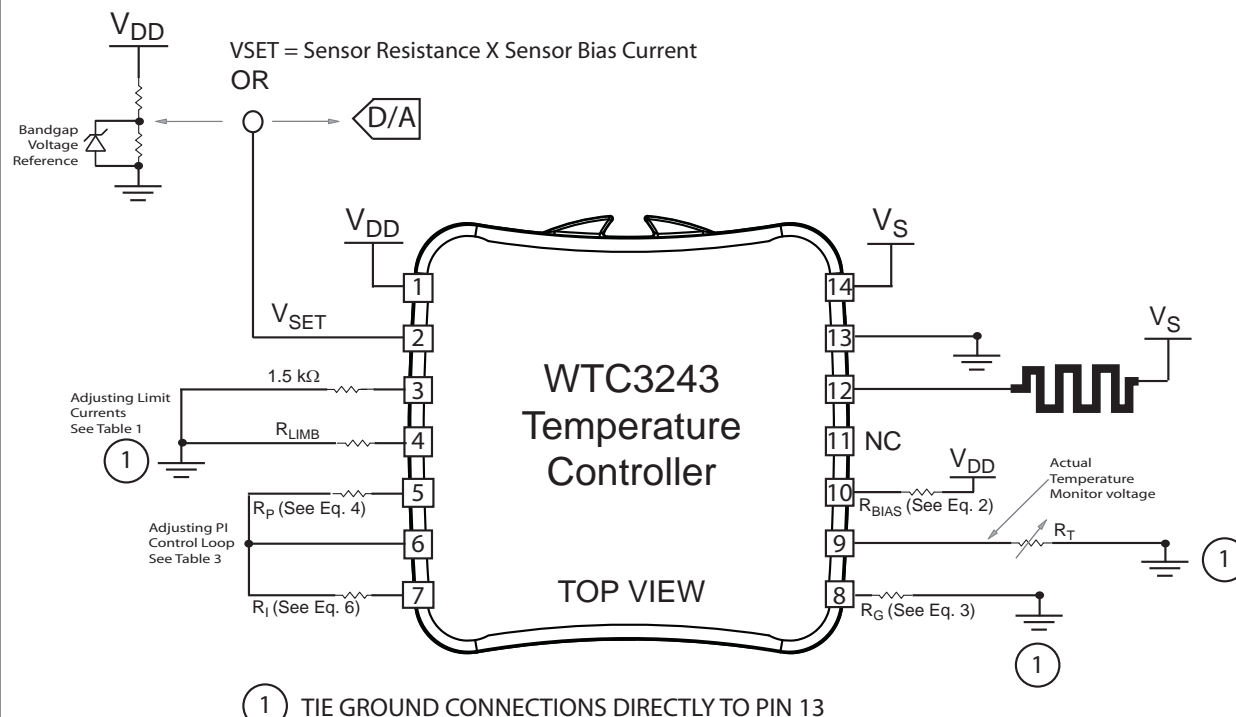

IF YOU ARE UPGRADING FROM THE WHY5640:

The position of Pin 1 on the WHY5640 is reversed (or mirrored) relative to the position of Pin 1 on the WTC3243.

9. OPERATING WITH RTD TEMPERATURE SENSORS

The following diagrams demonstrate how to configure the WTC3243 for operation with a Platinum RTD temperature sensor.

RTD / THERMOELECTRIC OPERATION -- TOP VIEW

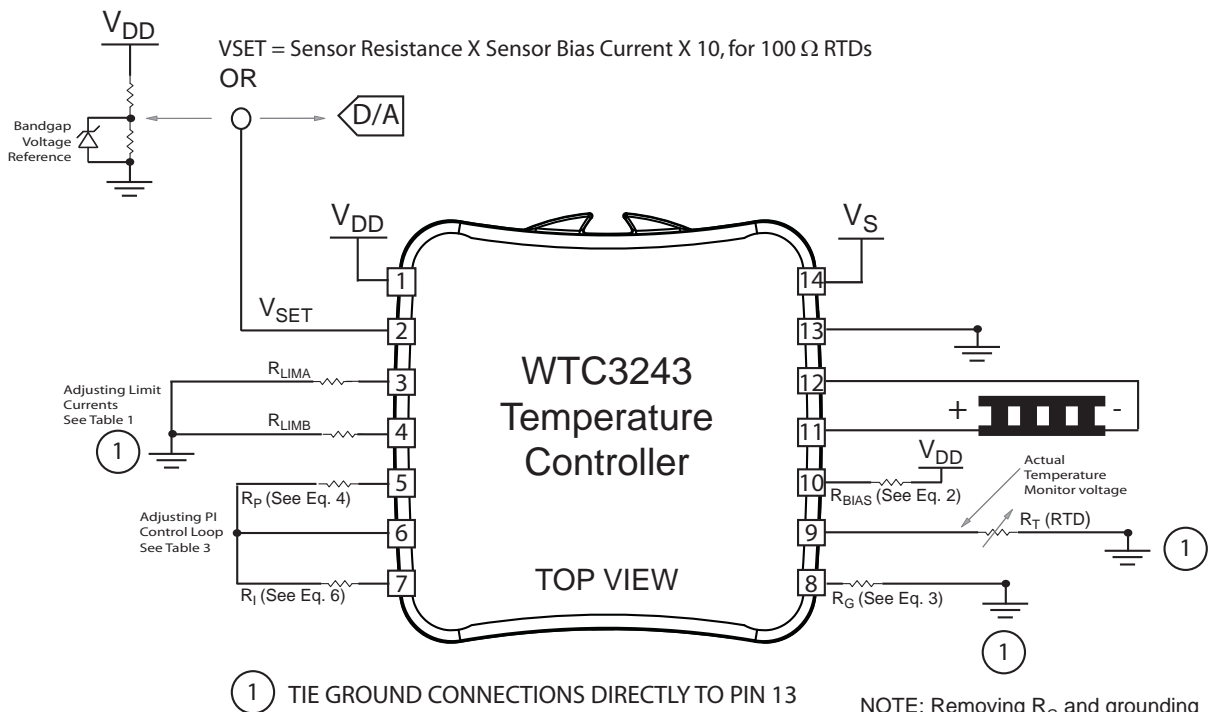

NOTE: Removing R_G and grounding Pin 8 will add an internal sensor gain of 10.09. Pin 9 will read 10 times less than Pin 2. If used with the evaluation PCB, Pin 9 will match Pin 2.

RTD / RESISTIVE HEATER OPERATION -- TOP VIEW

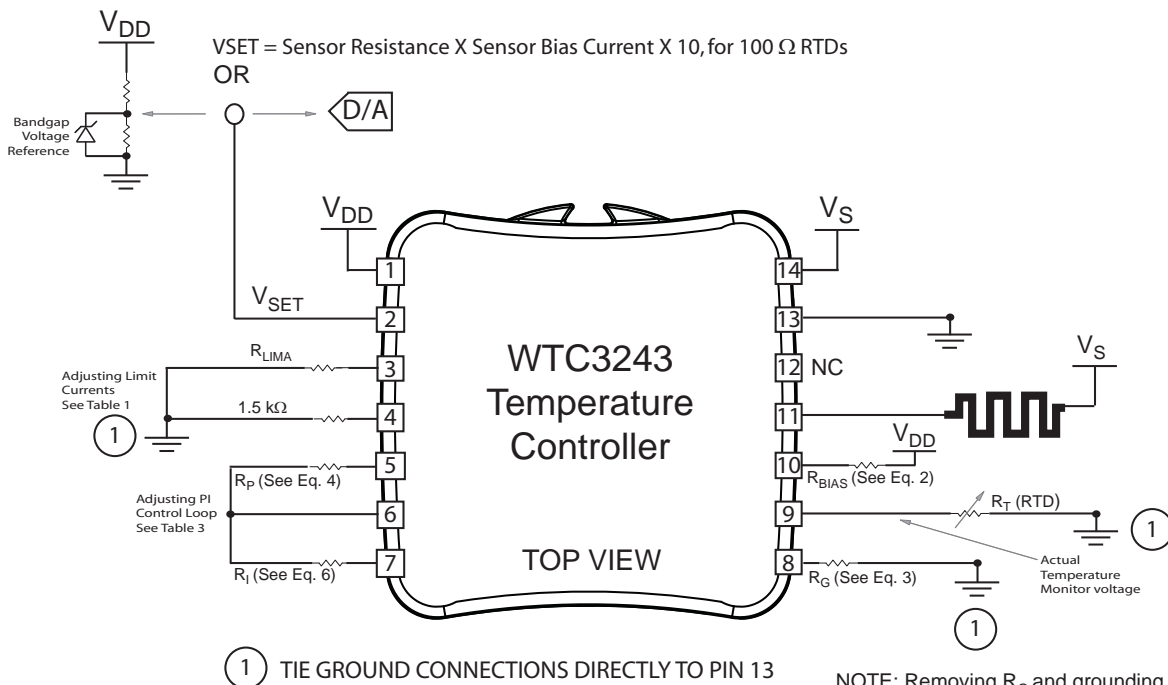

NOTE: Removing R_G and grounding Pin 8 will add an internal sensor gain of 10.09. Pin 9 will read 10 times less than Pin 2. If used with the evaluation PCB, Pin 9 will match Pin 2.

IF YOU ARE UPGRADING FROM THE WHY5640: The position of Pin 1 on the WHY5640 is reversed (or mirrored) relative to the position of Pin 1 on the WTC3243.

10. OPERATING WITH LM335 TYPE TEMPERATURE SENSORS

The following diagrams demonstrate how to configure the WTC3243 for operation with a National Semiconductor LM335 temperature sensor.

LM335 / THERMOELECTRIC OPERATION -- TOP VIEW

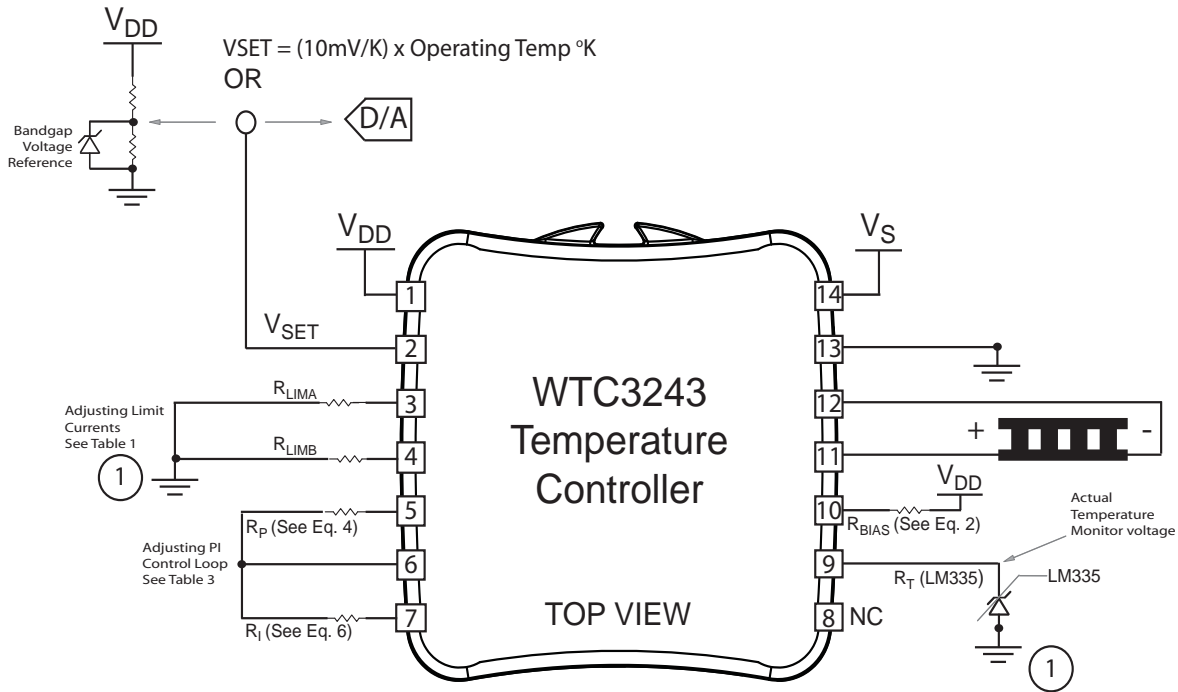

LM335 / RESISTIVE HEATER OPERATION -- TOP VIEW

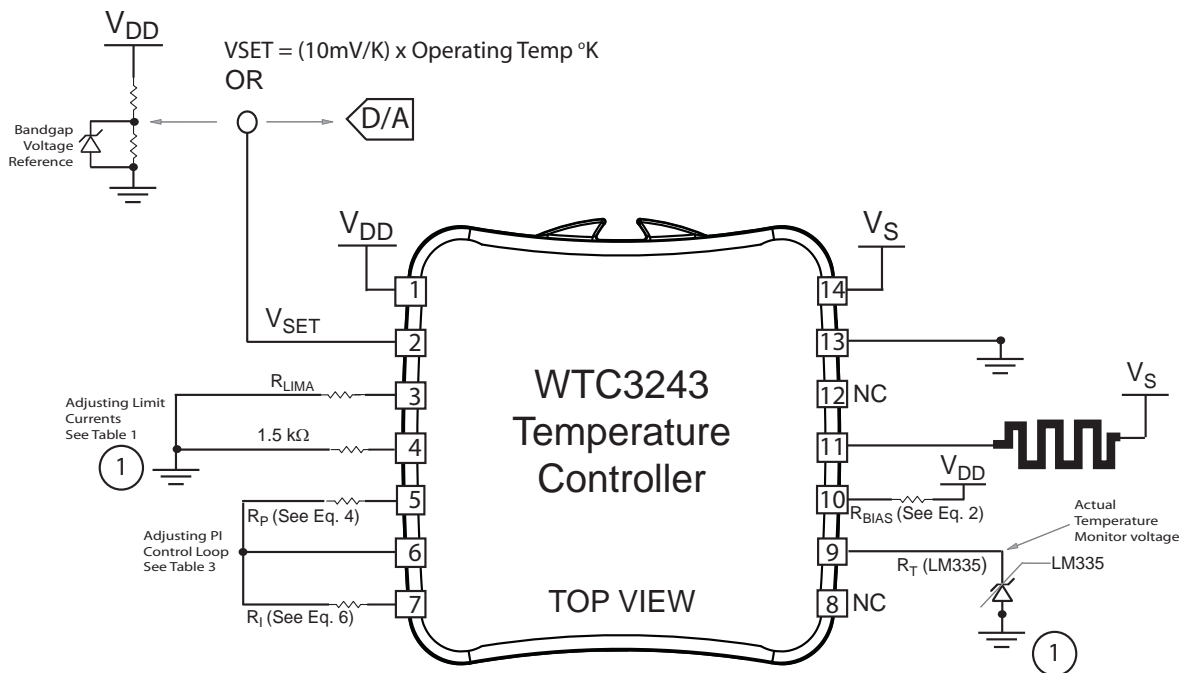

IF YOU ARE UPGRADING FROM THE WHY5640: The position of Pin 1 on the WHY5640 is reversed (or mirrored) relative to the position of Pin 1 on the WTC3243.

11. OPERATING WITH AD590 TYPE TEMPERATURE SENSORS

The following diagrams demonstrate how to configure the WTC3243 for operation with an Analog Devices AD590 Temperature Sensor.

AD590 / THERMOELECTRIC OPERATION -- TOP VIEW

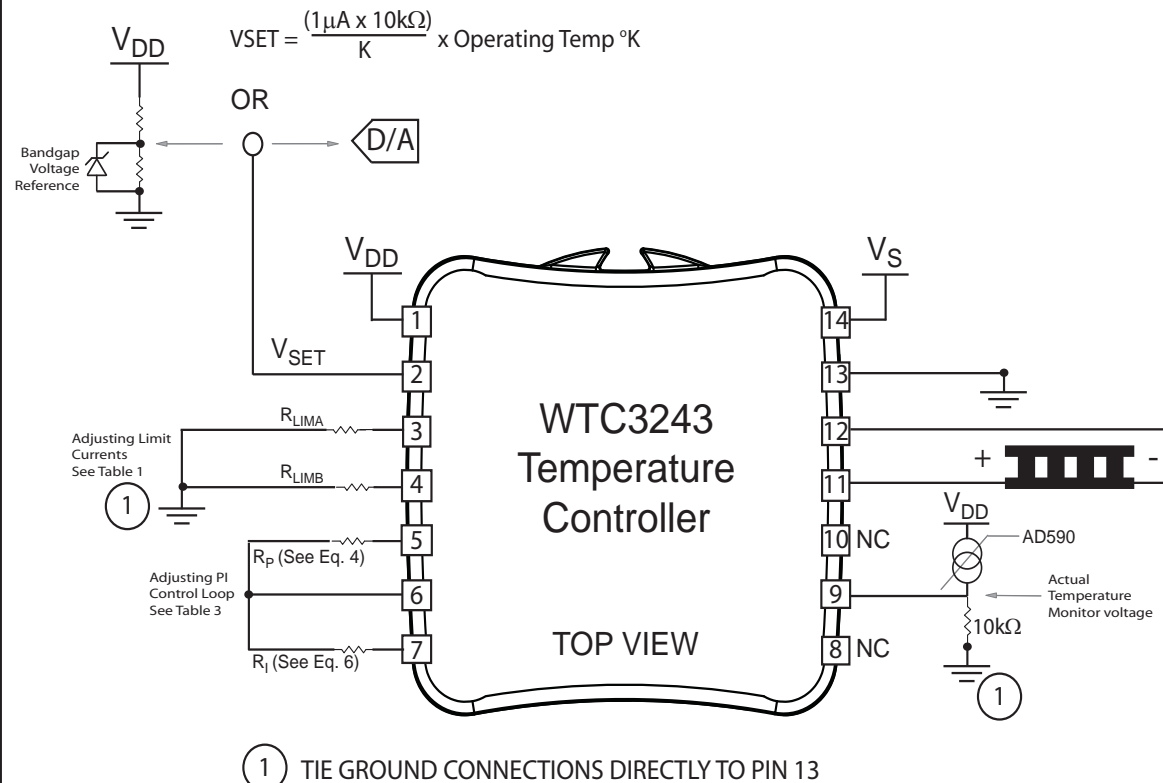

AD590 / RESISTIVE HEATER OPERATION -- TOP VIEW

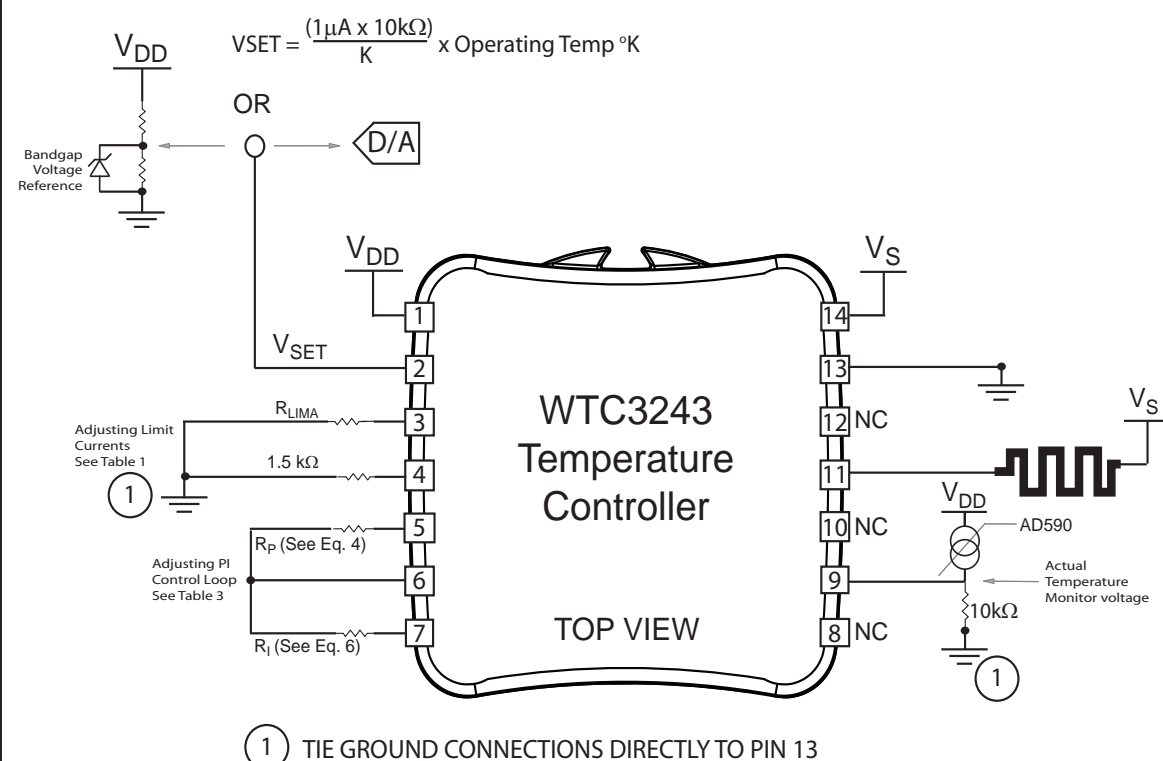

IF YOU ARE UPGRADING FROM THE WHY5640: The position of Pin 1 on the WHY5640 is reversed (or mirrored) relative to the position of Pin 1 on the WTC3243.

12. HELPFUL HINTS

Selecting a Temperature Sensor

Select a temperature sensor that is responsive around the desired operating temperature. The temperature sensor should produce a large change in sensor output for small changes in temperature. Sensor selection should maximize the voltage change per °C for best stability.

Table 5 compares temperature sensors versus their ability to maintain stable load temperatures with the WTC3243.

Mounting the Temperature Sensor

The temperature sensor should be in good thermal contact with the device being temperature controlled. This requires that the temperature sensor be mounted using thermal epoxy or some form of mechanical mounting and thermal grease.

Hint: Resistive temperature sensors and LM335 type temperature sensors should connect their negative termination directly to Pin 13 (GND) to avoid parasitic resistances and voltages effecting temperature stability and accuracy.

Avoid placing the temperature sensor physically far from the thermoelectric. This is typically the cause for long thermal lag and creates a sluggish thermal response that produces considerable temperature overshoot near the desired operating temperature.

Mounting the Thermoelectric

The thermoelectric should be in good thermal contact with its heatsink and load. Contact your thermoelectric manufacturer for their recommended mounting methods.

Heatsink Notes

If your device approaches the setpoint temperature but then drifts away from the setpoint temperature towards ambient, you may be experiencing a condition known as thermal runaway. This is caused by insufficient heat removal from the thermoelectric's hot plate and is most commonly caused by an undersized thermoelectric heatsink.

Ambient temperature disturbances can pass through the heatsink and thermoelectric and affect the device temperature stability. Choosing a heatsink with a larger mass and lower thermal resistance will improve temperature stability. Active cooling of the thermoelectric's heat sink may be required.

Table 5

Temperature Sensor Comparison

SENSOR	Thermistor	RTD	AD590	LM335
RATING	Best	Poor	Good	Good

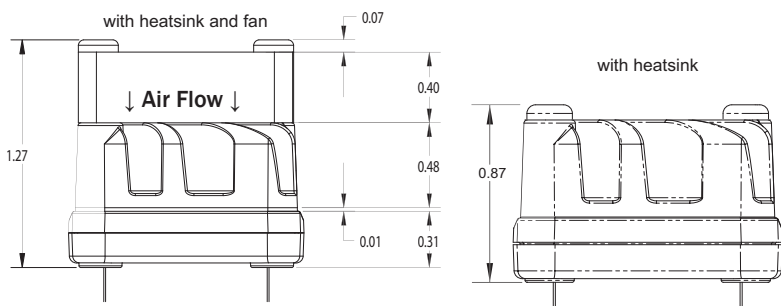

Weights

WTC3243	0.6 oz
WHS302 Heatsink	0.5 oz
WXC303/4 Fan	0.3 oz

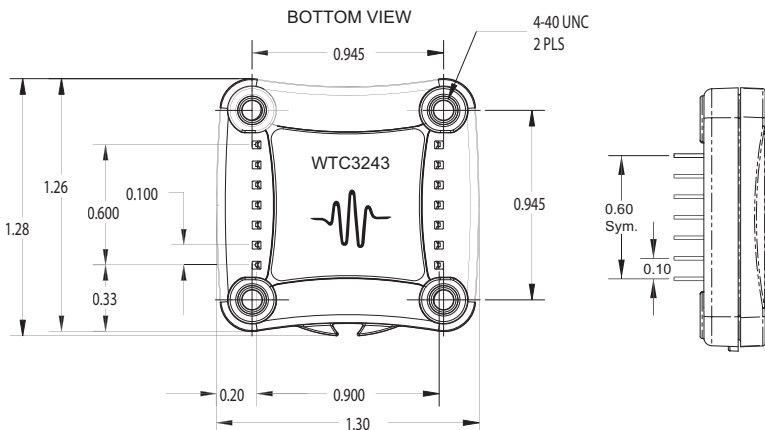

PIN DIAMETER: 0.020"
 PIN LENGTH: 0.126"
 PIN MATERIAL: Nickel Plated Steel
 HEAT SPREADER: Nickel Plated Aluminum
 PLASTIC COVER: LCP Plastic
 ISOLATION: 1200 VDC any pin to case
 THERMAL WASHER: WTW002
 HEATSINK: WHS320
 FANS: WXC303 (+5 VDC)
 or WXC304 (+12 VDC)

PCB FOOTPRINT

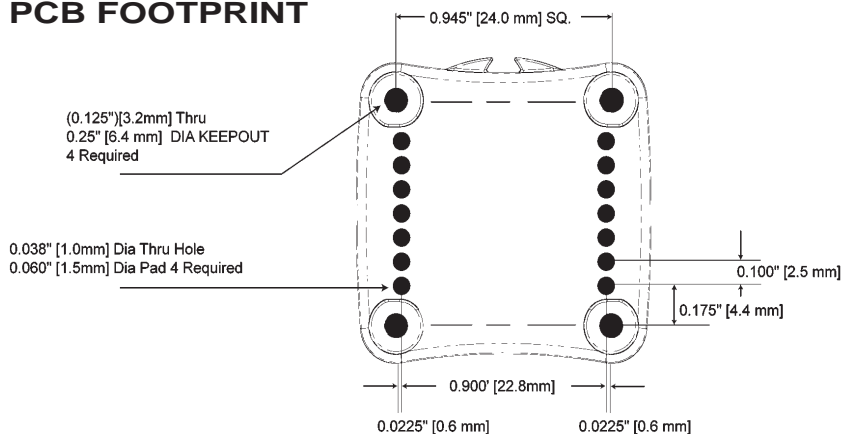

WTC3243 ASSEMBLED WITH HEATSINK & FAN

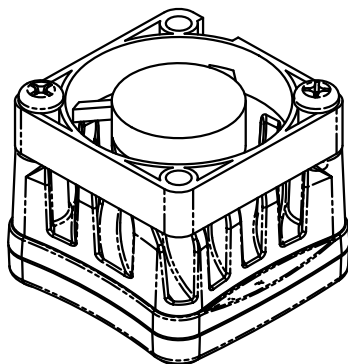

* Actual fan wire configuration may be different than shown.

Fan can be rotated on the WTC so the location of the wires matches your PCB layout.

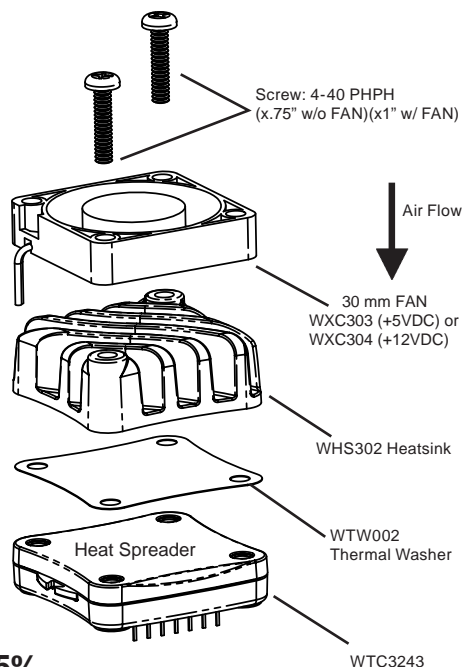

*All Tolerances are +/- 5%

CERTIFICATION:

Wavelength Electronics, Inc. (Wavelength) certifies that this product met it's published specifications at the time of shipment. Wavelength further certifies that its calibration measurements are traceable to the United States National Institute of Standards and Technology, to the extent allowed by that organization's calibration facilities, and to the calibration facilities of other International Standards Organization members.

WARRANTY:

This Wavelength product is warranted against defects in materials and workmanship for a period of 90 days from date of shipment. During the warranty period, Wavelength will, at its option, either repair or replace products which prove to be defective.

WARRANTY SERVICE:

For warranty service or repair, this product must be returned to the factory. An RMA is required for products returned to Wavelength for warranty service. The Buyer shall prepay shipping charges to Wavelength and Wavelength shall pay shipping charges to return the product to the Buyer upon determination of defective materials or workmanship. However, the Buyer shall pay all shipping charges, duties, and taxes for products returned to Wavelength from another country.

LIMITATIONS OF WARRANTY:

The warranty shall not apply to defects resulting from improper use or misuse of the product or operation outside published specifications.

No other warranty is expressed or implied. Wavelength specifically disclaims the implied warranties of merchantability and fitness for a particular purpose.

EXCLUSIVE REMEDIES:

The remedies provided herein are the Buyer's sole and exclusive remedies. Wavelength shall not be liable for any direct, indirect, special, incidental, or consequential damages, whether based on contract, tort, or any other legal theory.

REVERSE ENGINEERING PROHIBITED:

Buyer, End-User, or Third-Party Reseller are expressly prohibited from reverse engineering, decompiling, or disassembling this product.



WAVELENGTH ELECTRONICS, INC.

51 Evergreen Drive
 Bozeman, Montana, 59715
 phone: (406) 587-4910 Sales/Tech Support
 fax: (406) 587-4911
 e-mail: sales@teamWavelength.com
 web: www.teamWavelength.com

NOTICE:

The information contained in this document is subject to change without notice. Wavelength will not be liable for errors contained herein or for incidental or consequential damages in connection with the furnishing, performance, or use of this material. No part of this document may be photocopied, reproduced, or translated to another language without the prior written consent of Wavelength.

SAFETY:

There are no user serviceable parts inside this product. Return the product to Wavelength for service and repair to ensure that safety features are maintained.

LIFE SUPPORT POLICY:

As a general policy, Wavelength Electronics, Inc. does not recommend the use of any of its products in life support applications where the failure or malfunction of the Wavelength product can be reasonably expected to cause failure of the life support device or to significantly affect its safety or effectiveness. Wavelength will not knowingly sell its products for use in such applications unless it receives written assurances satisfactory to Wavelength that the risks of injury or damage have been minimized, the customer assumes all such risks, and there is no product liability for Wavelength. Examples of devices considered to be life support devices are neonatal oxygen analyzers, nerve stimulators (for any use), auto transfusion devices, blood pumps, defibrillators, arrhythmia detectors and alarms, pacemakers, hemodialysis systems, peritoneal dialysis systems, ventilators of all types, and infusion pumps as well as other devices designated as "critical" by the FDA. The above are representative examples only and are not intended to be conclusive or exclusive of any other life support device.

REVISION HISTORY		
REVISION	DATE	NOTES
REV. E	Dec-2007	Document Control release
REV. F	5-May-09	Updated to reflect on-ambient temperature stability performance improvements and updated limit current conversion table
REV. G	29-May-09	Corrected RTD polarity pg. 12
REV. H	31-Aug-09	Added I _{BIAS} selection criteria
REV. I	3-Jun-11	Updated mechanical specifications
REV. J	16-Dec-11	Updated mechanical specifications