



TCS10K5

10 kΩ NTC Cylindrical Head Thermistor



Graphic enlarged for detail

GENERAL DESCRIPTION:

This ±1% thermistor is encapsulated in a polyimide tube, for assemblies where surface mounting or embedding the thermistor is required. Ideal for tight mounting spaces with 38 AWG nickel bifilar leads and a diameter of 0.5 mm by 3 mm.

Thermal Resistance or Dissipation Constant is 0.2 mW / °C.

Thermal Time Constant is 200 mSec.

FEATURES:

- Low Cost
- Ideal for Optical or Thin Surfaces & Small Laser Packages
- 1% Tolerance
- 3" Long Nickel Bifilar Leads
- Isolated Leads Provide Isolation from Metal Housing
- RoHS Compliant

Thermistor Selection Guide			
MODEL	R @ 25°C	10 μA RANGE	100 μA RANGE
TCS605	5 kΩ	-55 to -2°C	-20 to +33°C
TCS610	10 kΩ	-45 to +13°C	-8 to +50°C
TCS10K5	10 kΩ	-45 to +13°C	-8 to +50°C
TCS620	20 kΩ	-35 to +28°C	+6 to +69°C
TCS650	50 kΩ	-18 to +49°C	+25 to +92°C
TCS651	100 kΩ	-6 to +67°C	+41 to +114°C

Figure 1
Dimensions

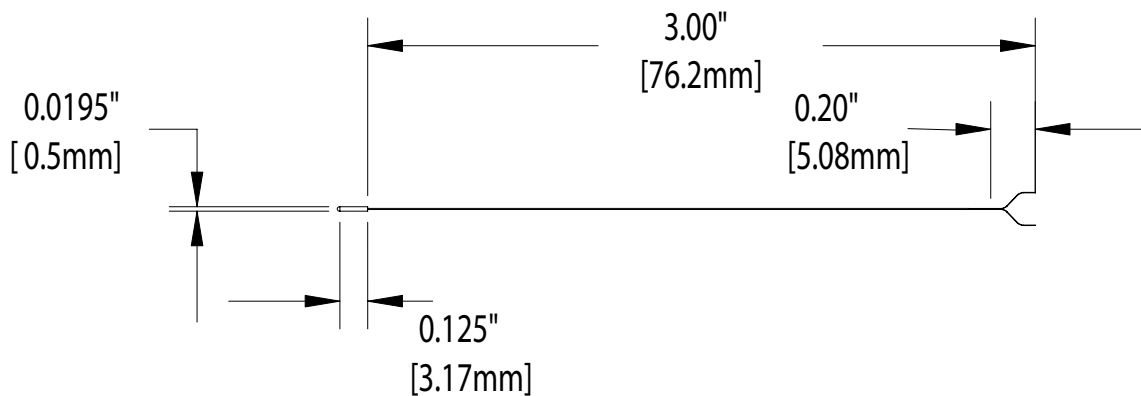

RESISTANCE VERSUS TEMPERATURE RESPONSE

TCS10K5 10 kΩ THERMISTOR @ 25°C

10 μA TEMPERATURE RANGE: -45 to +13°C

100 μA TEMPERATURE RANGE: -8 to +50°C

TEMP (°C)	R _T (Ω)	VOLT (V) (10 μA)	VOLT (V) (100 μA)	TEMP (°C)	R _T (Ω)	VOLT (V) (10 μA)	VOLT (V) (100 μA)	TEMP (°C)	R _T (Ω)	VOLT (V) (10 μA)	VOLT (V) (100 μA)
-45	473200	4.732		-13	65260	0.652		19	13070		1.307
-44	441800	4.418		-12	61750	0.617		20	12490		1.249
-43	412600	4.126		-11	58450	0.584		21	11940		1.194
-42	385600	3.856		-10	55340	0.553		22	11420		1.142
-41	360500	3.605		-9	52420	0.524		23	10920		1.092
-40	337200	3.372		-8	49670	0.496	4.967	24	10450		1.045
-39	315500	3.155		-7	47080	0.470	4.708	25	10000		1.000
-38	295400	2.954		-6	44640	0.446	4.464	26	9572		0.957
-37	276700	2.767		-5	42340	0.423	4.234	27	9165		0.916
-36	259300	2.593		-4	40170	0.401	4.017	28	8777		0.877
-35	243100	2.431		-3	38120	0.381	3.812	29	8408		0.840
-34	228000	2.280		-2	36200	0.362	3.620	30	8056		0.805
-33	213900	2.139		-1	34380	0.343	3.438	31	7721		0.772
-32	200800	2.008		0	32660	0.326	3.266	32	7402		0.740
-31	188600	1.886		1	31040	0.310	3.104	33	7098		0.709
-30	177200	1.772		2	29510	0.295	2.951	34	6808		0.680
-29	166500	1.665		3	28060	0.280	2.806	35	6531		0.653
-28	156600	1.566		4	26690	0.266	2.669	36	6267		0.626
-27	147300	1.473		5	25400	0.254	2.540	37	6015		0.601
-26	138600	1.386		6	24180	0.241	2.418	38	5774		0.577
-25	130500	1.305		7	23020	0.230	2.302	39	5545		0.554
-24	122900	1.229		8	21920	0.219	2.192	40	5326		0.532
-23	115800	1.158		9	20890	0.208	2.089	41	5116		0.511
-22	109200	1.092		10	19900	0.199	1.990	42	4916		0.491
-21	103000	1.030		11	18970	0.189	1.897	43	4725		0.472
-20	97130	0.971		12	18090	0.180	1.809	44	4543		0.454
-19	91660	0.916		13	17260	0.172	1.726	45	4368		0.436
-18	86540	0.865		14	16470		1.647	46	4201		0.420
-17	81730	0.817		15	15710		1.571	47	4041		0.404
-16	77220	0.772		16	15000		1.500	48	3888		0.388
-15	72980	0.729		17	14320		1.432	49	3742		0.374
-14	69000	0.690		18	13680		1.368	50	3602		0.360

You can approximate the response of a thermistor with the Steinhart-Hart Equation. The A, B, and C values listed below apply to the following equation. The coefficients are optimized for the ranges covered by the reference currents.

$$\frac{1}{T} = A + B \times \ln R + C \times (\ln R)^3, \text{ where } R \text{ is in ohms and } T \text{ is in Kelvin}$$

Steinhart-Hart Coefficients			
10 μA RANGE		100 μA RANGE	
A	1.1235E-03	A	1.1279E-03
B	2.3500E-04	B	2.3429E-04
C	8.4538E-08	C	8.7298E-08

CERTIFICATION:

Wavelength Electronics (Wavelength) certifies that this product met it's published specifications at the time of shipment. Wavelength further certifies that its calibration measurements are traceable to the United States National Institute of Standards and Technology, to the extent allowed by that organization's calibration facilities, and to the calibration facilities of other International Standards Organization members.

WARRANTY:

This Wavelength product is warranted against defects in materials and workmanship for a period of 90 days from date of shipment. During the warranty period, Wavelength will, at its option, either repair or replace products which prove to be defective.

WARRANTY SERVICE:

For warranty service or repair, this product must be returned to the factory. An RMA is required for products returned to Wavelength for warranty service. The Buyer shall prepay shipping charges to Wavelength and Wavelength shall pay shipping charges to return the product to the Buyer upon determination of defective materials or workmanship. However, the Buyer shall pay all shipping charges, duties, and taxes for products returned to Wavelength from another country.

LIMITATIONS OF WARRANTY:

The warranty shall not apply to defects resulting from improper use or misuse of the product or operation outside published specifications.

No other warranty is expressed or implied. Wavelength specifically disclaims the implied warranties of merchantability and fitness for a particular purpose.

EXCLUSIVE REMEDIES:

The remedies provided herein are the Buyer's sole and exclusive remedies. Wavelength shall not be liable for any direct, indirect, special, incidental, or consequential damages, whether based on contract, tort, or any other legal theory.

NOTICE:

The information contained in this document is subject to change without notice. Wavelength will not be liable for errors contained herein or for incidental or consequential damages in connection with the furnishing, performance, or use of this material. No part of this document may be photocopied, reproduced, or translated to another language without the prior written consent of Wavelength.

SAFETY:

There are no user serviceable parts inside this product. Return the product to Wavelength for service and repair to ensure that safety features are maintained.

LIFE SUPPORT POLICY:

As a general policy, Wavelength Electronics, Inc. does not recommend the use of any of its products in life support applications where the failure or malfunction of the Wavelength product can be reasonably expected to cause failure of the life support device or to significantly affect its safety or effectiveness. Wavelength will not knowingly sell its products for use in such applications unless it receives written assurances satisfactory to Wavelength that the risks of injury or damage have been minimized, the customer assumes all such risks, and there is no product liability for Wavelength. Examples of devices considered to be life support devices are neonatal oxygen analyzers, nerve stimulators (for any use), auto transfusion devices, blood pumps, defibrillators, arrhythmia detectors and alarms, pacemakers, hemodialysis systems, peritoneal dialysis systems, ventilators of all types, and infusion pumps as well as other devices designated as "critical" by the FDA. The above are representative examples only and are not intended to be conclusive or exclusive of any other life support device.

REVISION HISTORY		
REVISION	DATE	NOTES
REV. A	30-Jun-08	Added technical detail per customer request
REV. B	25-Sep-09	Updated to reflect RoHS status



WAVELENGTH ELECTRONICS, INC.
51 Evergreen Drive
Bozeman, Montana, 59715

phone: (406) 587-4910 Sales/Tech Support
fax: (406) 587-4911
e-mail: sales@teamwavelength.com
web: www.teamwavelength.com