



PLD-CH Series Laser Diode Drivers - Chassis Mount Version



GENERAL DESCRIPTION

The **PLD** series of Laser Diode Drivers combines the high performance you expect from a Wavelength component with two distinct improvements: low voltage operation from +5 V DC, and an **Active Current Limit**.

Operating from a single +5 V supply minimizes heat dissipation. Modular packaging makes it easy to integrate the PLD into your system. For applications that require a higher forward voltage, a separate laser diode power supply input lets you provide a higher compliance voltage. The **Active Current Limit** not only protects your laser diode, but ensures that you are operating with maximum stability. When the laser current reaches the level set by the Limit I Trimpot, the output disables and the Limit LED and Limit Status indicate the current limit has been reached.

Two photodiode ranges provide variable sensitivities for optimum operation. You can maintain excellent stability when operating in both constant current and constant power mode. All trimpots and switches are easily accessible and offer precision control. A slow start circuit, mechanical shorting relay, and Active Current Limit offer maximum protection for your laser diode even when power is removed.

FEATURES

- 5 A, 10 A, and 12.5 A models, parallel for up to 25 A
- Single supply operation: +5 VDC
- Separate Laser Diode Supply input allows for flexible compliance voltages up to +28 VDC typical (Consult the online Safe Operating Area (SOA) calculator for supply voltages exceeding +5 VDC: <http://www.teamwavelength.com/support/calculator/soa/soald.php>)
- Manually adjust:
 - Setpoint & Current Limit
 - Constant Current or Constant Power Operation
 - Photodiode Sensitivity
- Remotely:
 - Adjust Setpoint Current with Analog Input
 - Enable or Disable Output
 - Monitor Laser Diode Current, Photodiode Current, and Laser Diode Limit Current
 - Monitor Limit Status
- Supports all laser diode / photodiode pin configurations
- Safety is maximized:
 - Slow start circuitry
 - Mechanical relay protects even when power is removed or current is disabled
 - Active Current Limit

Ordering Information

PLD5K-CH	5 A Laser Diode Driver
PLD10K-CH	10 A Laser Diode Driver
PLD12.5K-CH	12.5 A Laser Diode Driver
WCB308	Power / LD Cable Set

Figure 1
Pin Layout and Descriptions (Top View)

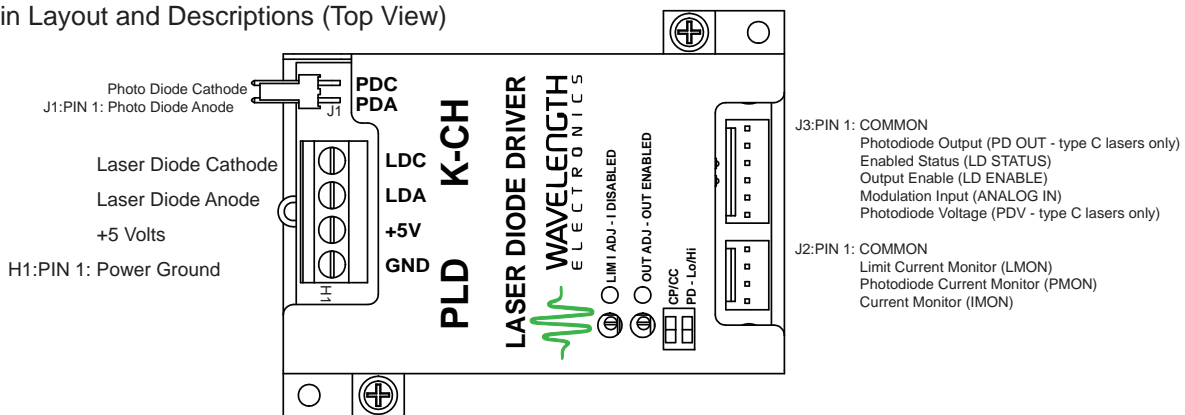
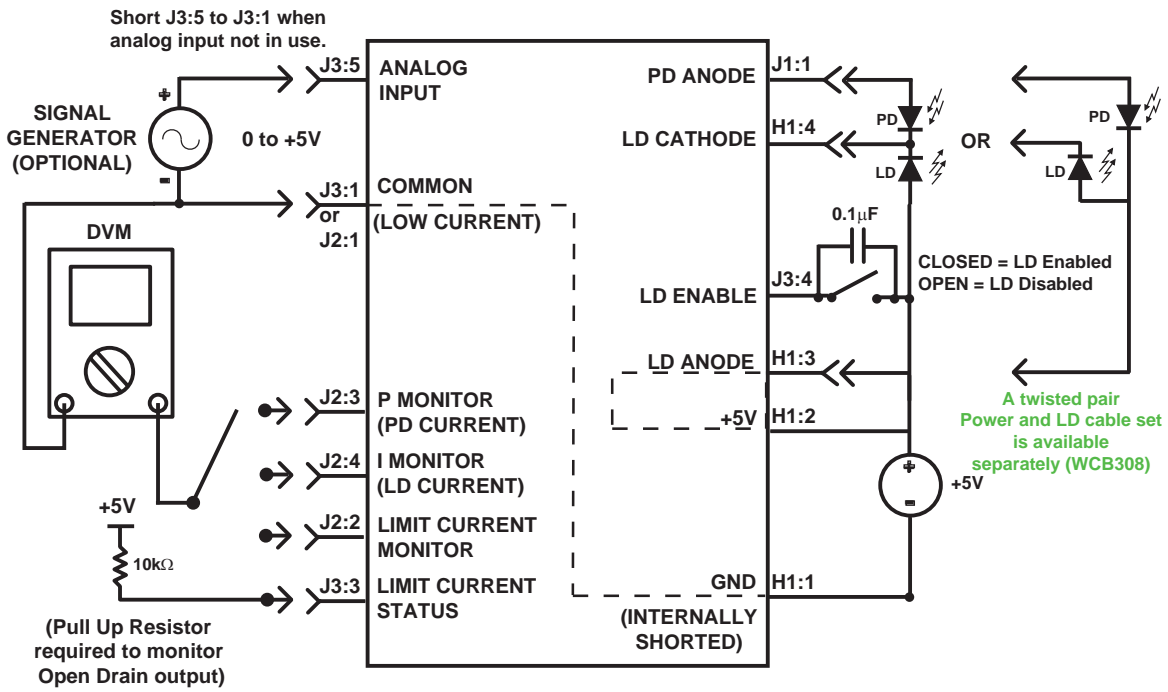

Figure 2
Quick Connect
Type A/B Laser Diode



PLD5K-CH / PLD10K-CH / PLD12.5K-CH CHASSIS MOUNT LASER DIODE DRIVERS

ELECTRICAL AND OPERATING SPECIFICATIONS

PLD5K-CH / PLD10K-CH / PLD12.5K-CH CHASSIS MOUNT LASER DIODE DRIVERS

ABSOLUTE MAXIMUM RATINGS RATING	SYMBOL	VALUE	UNIT
Supply Voltage	+ 5 V (HI:2)	+5 to +5.5	Volts DC
Supply Voltage (LDA High Compliance)	LD Anode (HI:3)	+4.5 to +30 ⁷ ⁸	Volts DC
Supply Voltage (Type C Laser)	AUX V+ for PDV	+8 to +12.5	Volts DC
Operating Temperature (typical) ⁶	T _{OPR}	0 to +50	°C
Storage Temperature	T _{STG}	-55 to +125	°C
Weight		< 3.2	ounces
Size		1.14 x 2.35 x 2.9	inches

PARAMETER	TEST CONDITIONS	MODEL			UNITS
		PLD5K	PLD10K	PLD12.5K	
DRIVE CURRENT OUTPUT					
Output Current Max (see SOA Chart)		5	10 ⁵	12.5 ⁵	A
Compliance Voltage ¹	+5 V Input	< 3	< 3	< 3	V
Compliance Voltage ¹	+30 V Input	< 28	< 28	< 28	V
Temperature Coefficient		< 200	< 200	< 200	ppm / °C
Short Term Stability, 1 hour		< 100	< 200	< 200	ppm
PHOTODIODE FEEDBACK					
High Range ²		50-5000	50-5000	50-5000	μA
Low Range (Type A & B ONLY) ²		15-500	15-500	15-500	μA
Constant Power Output Stability		< 0.02	< 0.05	< 0.05	%
EXTERNAL MODULATION					
Input Impedance		1	1	1	MΩ
Transfer Function	0 to +5 V	1	2.3	2.5	A / V
Analog In Damage Limits	-0.5 V < ANALOG IN < Supply Voltage (+5 V in) + 0.5V				
Bandwidth, 3 dB ²		120	80	50	kHz
90 % Depth of Modulation ³		70	70	40	kHz
POWER SUPPLY ⁴					
Maximum Internal Power Dissipation		40	40	40	W
Quiescent Current		150	250	250	mA
MONITOR ACCURACY					
Monitor Voltage versus expected output current based on transfer function		2	2	2	% full scale

¹ Compliance Voltage will vary depending on power supply voltages. In high compliance mode, a maximum compliance voltage of +28 volts will be obtained with +30 volts input. A maximum compliance voltage of +3 volts will be obtained with +5 volts input. See page 9 for more detail.

² Photodiode response determines the modulation bandwidth in Constant Power mode. PD response can vary widely from manufacturer to manufacturer.

³ As pulse frequency increases on the analog input, the peak-to-peak output amplitude diminishes. For example, these graphs show the waveform shape at 10 Hz and 70 kHz. Depth of modulation continues to decrease after 70 kHz. Note: 90% DOM for PLD12.5K-CH is at 40 kHz.

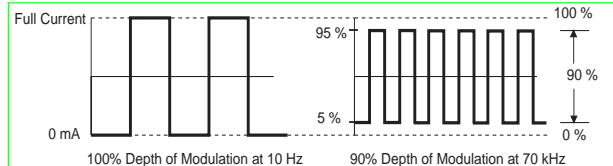

⁴ If a thermistor or TE module are case common with the laser diode, the PLD and temperature controller power supplies may need to be isolated from each other or a bipolar supply may be required.

⁵ To drive above 10 A, you may need to increase supply voltage to 5.5 V. Cable impedance at these currents may reduce voltage to the unit or to the load.

⁶ Maximum operating temperature for the PLD12.5K-CH is 35°C.

⁷ For PLD12.5K-CH, Supply Voltage (+5 V) and LDA Voltage must come from separate supplies.

⁸ Consult the online Safe Operating Area (SOA) calculator for supply voltages exceeding +5 VDC:
<http://www.teamwavelength.com/support/calculator/soa/soald.php>

NOTE: Specifications for Rev. B of the PLD-CH family can be found on page 5.

PIN DESCRIPTIONS

CONNECTOR	PIN	NAME	DESCRIPTION
H1	1	GND	Power supply ground. Used with +5 V input for high current return.
	2	+5V	Supply voltage to control electronics. Min +4.5 V Max +5.5 V For PLD12.5K, Supply Voltage (+5 V) and LDA Voltage must come from separate supplies.
	3	LDA	Laser Diode Anode and laser diode supply connection. Recommended +LD Supply for single laser is +5 V. Maximum +30 V. In the default configuration a purple jumper wire is connected between pins 2 and 3 for +5 Volt operation. CAUTION: Too high a voltage may damage the PLD. For PLD12.5K, Supply Voltage (+5 V) and LDA Voltage must come from separate supplies.
	4	LDC	Laser Diode Cathode
J1	1	PDA	Photodiode Anode - For Type A or B laser diodes. See page 11 for use with Type C laser diode packages.
	2	PDC	Photodiode Cathode - For TYPE C laser diodes only. See page 11.
J2	1	COMMON	Measurement ground. Low current return used only with MONITOR pins and ANALOG INPUT . Shorted to GND pin internally.
	2	LMON	Current Limit Setpoint Monitor. Impedance: 1 kΩ, Output: 0 to 2.5 V NOTE: Current limit needs to be set 0.2 V above desired limit level. See additional notes on page 14 for fine tuning the current limit.
	3	PMON	Power Monitor (PD Current Monitor). Impedance: 1 kΩ, Output: 0 to 2.5 V
	4	IMON	Laser Diode Current Monitor. Impedance: 1 kΩ, Output: 0 to 2.5 V
J3	1	COMMON	Measurement ground. Low current return used only with MONITOR pins and ANALOG INPUT . Shorted to GND pin internally.
	2	PD OUT	Photodiode Output - For TYPE C laser diode packages only. See page 11.
	3	LD STATUS	LIMIT status. LIMIT < 0.3 Volts Normal Operation = High Impedance If Limit is detected, laser diode current will turn off, Limit I LED will light. Toggle LD ENABLE to restart laser diode current.
	4	LD ENABLE	Enable Output Current = +3 to +5 V Not TTL-compatible. Disable Output Current = Ground or Floating (Requires 5 mA.)
	5	ANALOG IN	Remote setpoint or modulation input. Input impedance = 1 MΩ Input 0 to 5 V. Connect ANALOG INPUT to COMMON when not in use. Signal must be between -0.5 V and [Supply Voltage (+5 V) + 0.5 V] to avoid damaging the electronics.
	6	PDV	Photodiode Voltage - For TYPE C laser diode packages only. See page 11.

NOTE for REV. A:

A single connector is used in place of the terminal block and PD connector. Pin-out is shown at right. Revision A products will have an "A" as the third digit in the lot number.

Example: **CHA0852111**

revision

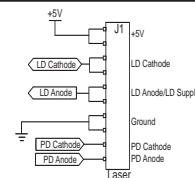

LASER DIODE TYPES

The following laser diode / photodiode configurations are common - Type A, Type B, and Type C. Setup and operation vary according to your type of laser diode. **Please identify which laser diode you will be using with the PLD and follow the appropriate operating instructions.**

Operating instructions for lasers of Type A or B are detailed on pages 8-10.

Operating instructions for Type C Lasers are detailed on pages 11-12.

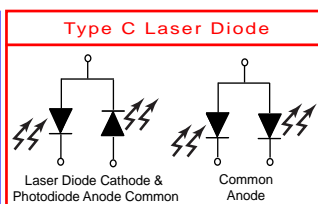
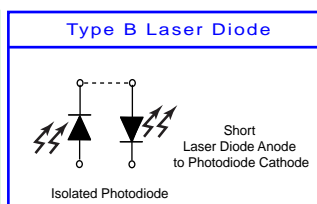
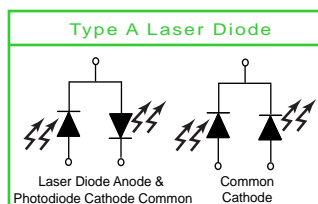

Timing Characteristics

Revision C				
Symbol	Parameter	Test Points	Test Conditions	Typ
t_{ON}	On Time	Load	PLD5KCH	4.8 μ sec
			PLD10KCH	5.9 μ sec
			PLD12.5KCH	8 μ sec
t_{OFF}	Off Time	Load	PLD5KCH	9.4 μ sec
			PLD10KCH	10 μ sec
			PLD12.5KCH	9 μ sec
$t_{SLOWSTART}$	Slow Start	Load	PLD5KCH	1.5 sec
			PLD10KCH	1.5 sec
			PLD12.5KCH	1.5 sec

Revision B			
Symbol	Parameter	Test Conditions	Typ
t_{ON}	On Time	PLD5KCH	6.8 μ sec
		PLD10KCH	10 μ sec
t_{OFF}	Off Time	PLD5KCH	6.8 μ sec
		PLD10KCH	12 μ sec
$t_{SLOWSTART}$	Slow Start	PLD5KCH	1.5 sec
		PLD10KCH	1.5 sec

Test Setup for Parameter Measurement

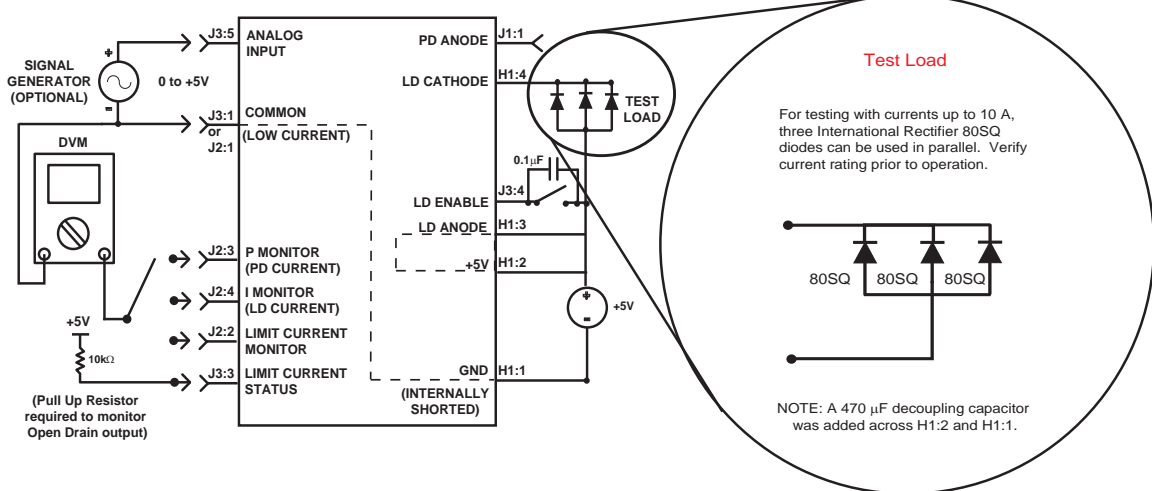

Slow Start Timing

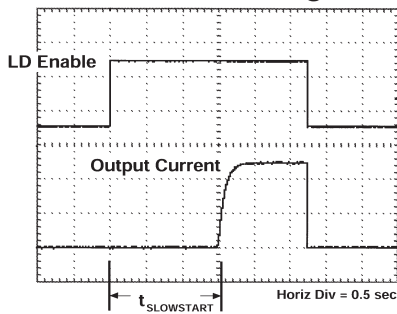

Typical large signal frequency response

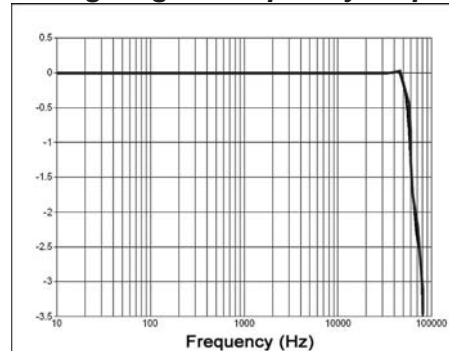

10 kHz square wave response

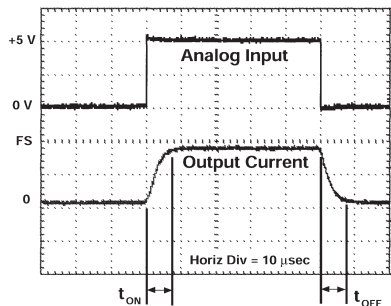

Current Limit Operation

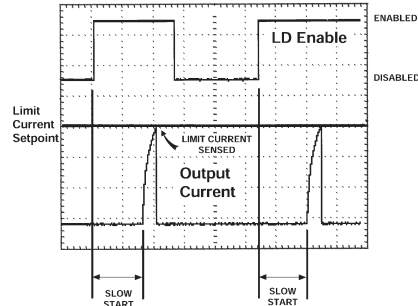

SAFE OPERATING AREA & HEATSINK REQUIREMENTS

Caution:

Do not exceed the Safe Operating Area (SOA). Exceeding the SOA voids the warranty.

An online tool is available for calculating Safe Operating Area at:

<http://www.teamwavelength.com/support/calculator/soa/soald.php>.

To determine if the operating parameters fall within the SOA of the device, the maximum voltage drop across the controller and the maximum current must be plotted on the SOA curves.

These values are used for the example SOA determination:

Device: PLD 5KCH

V_{LDA} (H1:2) = 10 volts

V_{LD} = 5 volts

I_{LD} = 2.25 amps

} These values are determined from the specifications of the laser diode.

Follow these steps:

1. Determine the maximum voltage drop across the driver, $V_{LDA} - V_{LD}$, and mark on the X axis.
Example: 10 volts - 5 volts = 5 volts (Point A)
2. Determine the maximum current, I_{LD} , through the laser diode and mark on the Y axis:
(2.25 amps, Point B)
3. Draw a horizontal line through Point B across the chart. (Line BB)
4. Draw a vertical line from Point A to the maximum current line indicated by Line BB.
5. Mark V_{LDA} on the X axis. (Point C)
6. Draw the Load Line from where the vertical line from point A intersects Line BB down to Point C.

Refer to the chart shown below and note that the Load Line is within the Safe Operating Area for this device.

Better thermal performance can be achieved at higher currents by providing airflow across the the electronics as well as the chassis. The cover deliberately leaves the connector ends exposed for airflow. A heatsink must be properly attached to the PLD-CH in order to remove heat from the module. Use the SOA Calculator to determine the maximum power dissipated in the unit. Calculate the required thermal resistance rating (R) for the heatsink, where P_{PLD} is the power dissipated internal to the PLD:

$$R = \frac{125}{P_{PLD}} - 1.56 \text{ [}^\circ\text{C/W]}$$

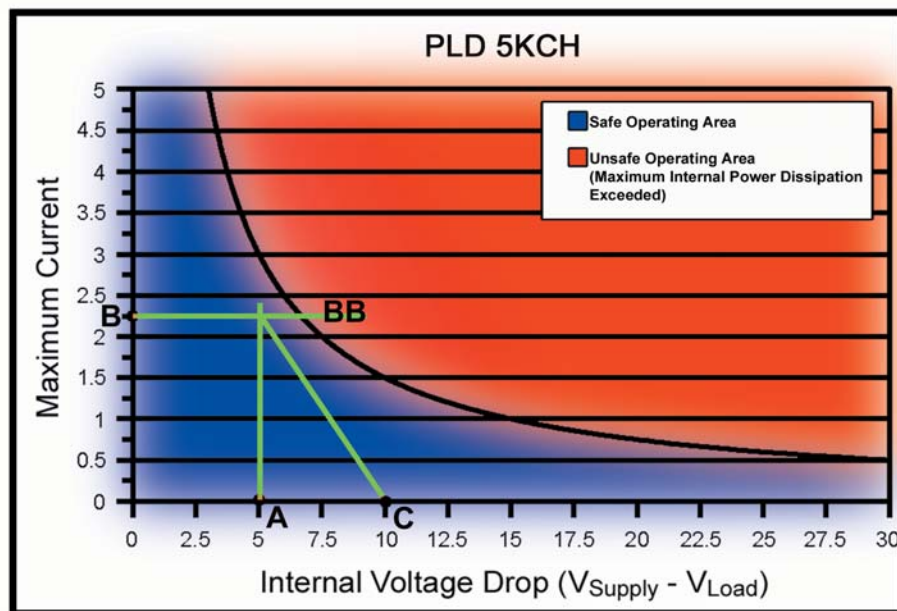

Derate maximum power dissipation 1.3 Watts / $^\circ\text{C}$ for chassis temperatures above 55 $^\circ\text{C}$

SAFE OPERATING AREA CHARTS

The charts on this page can be used to determine if your design falls within the **Safe Operating Area** (SOA) for the PLD series driver that you are using. For an example of how to use these charts, reference the previous page. There is also an online Safe Operating Area calculator available at <http://www.teamwavelength.com/support/calculator/soa/soald.php>.

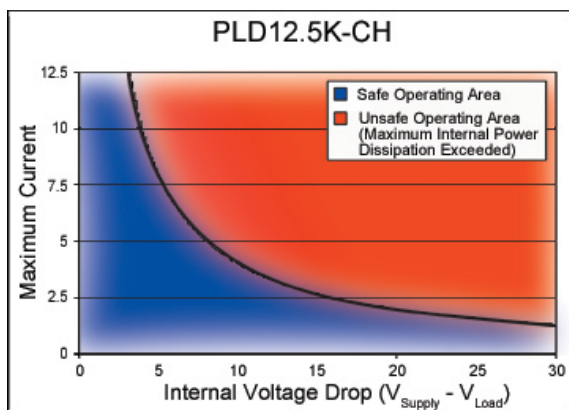
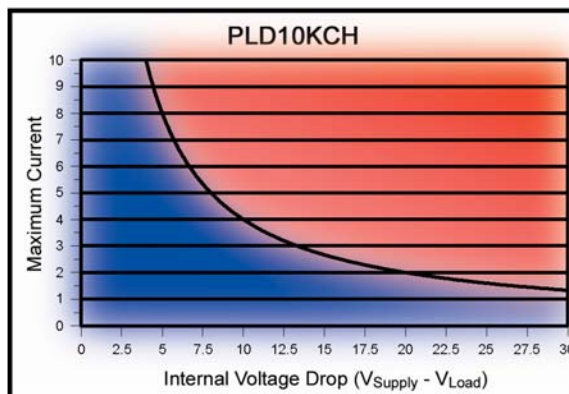
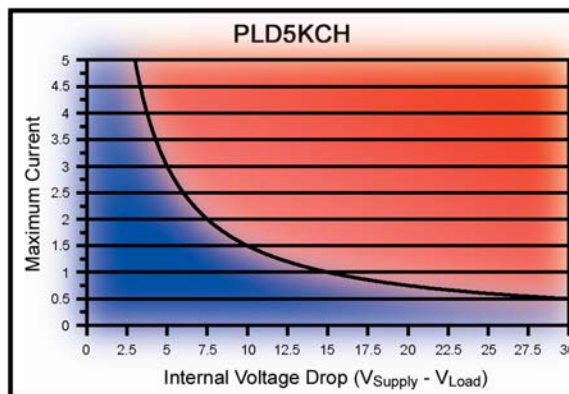

PLD5K-CH / PLD10K-CH / PLD12.5K-CH CHASSIS MOUNT LASER DIODE DRIVERS

+5V OPERATION

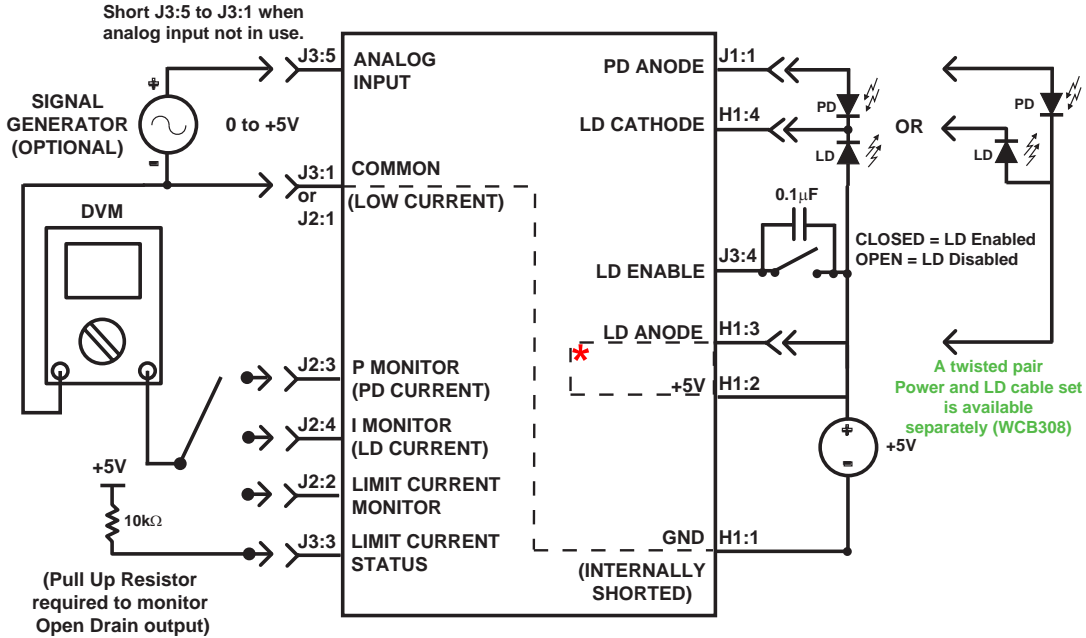

* Note: In the default configuration, pins 2 and 3 on H1 are jumpered. The PLDxx-CH drivers are shipped in this configuration. Since this jumper makes the connection between these pins, it eliminates the need for the user to connect the pins.

Because 12.5K operation requires separate supplies, on the PLD12.5K-CH, this jumper is removed at the factory.

EXTERNAL ADJUSTMENTS

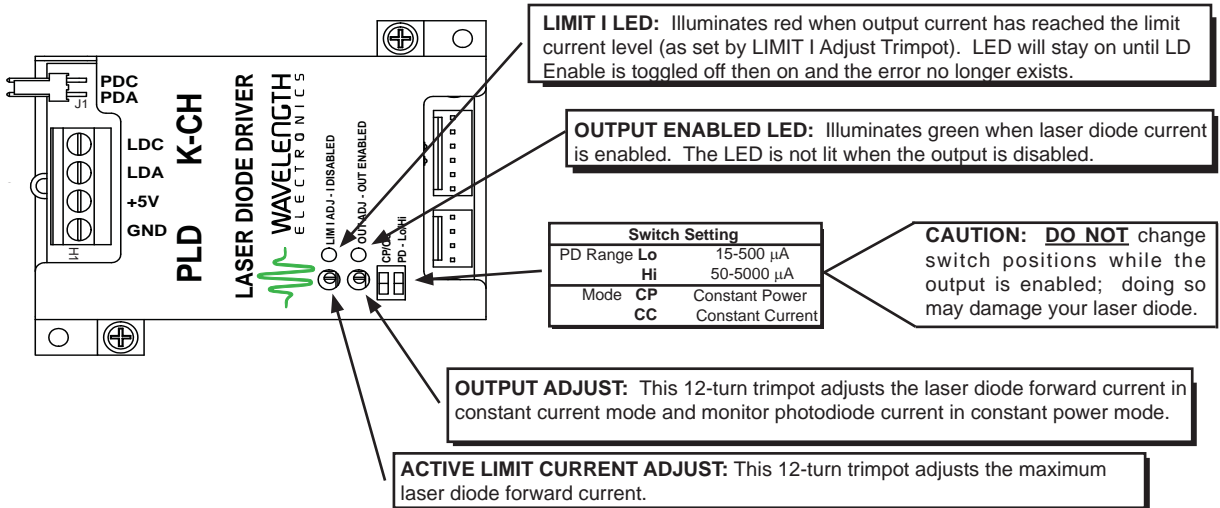

PLD5K-CH / PLD10K-CH / PLD12.5K-CH CHASSIS MOUNT LASER DIODE DRIVERS

CONSTANT CURRENT MODE

With the Output Disabled:

- (1) **Configure Mode Switch to CC.** [switch on top of PLD]
- (2) **Set Limit Current:** Monitor the **LMON** (J2:2) voltage and adjust the **LIM I** trimpot clockwise (CW) until the voltage on **LMON** corresponds to the desired level.

NOTE: The current limit circuit triggers slightly before the expected limit level. To fine tune the limit, add an offset voltage to the setting per the equation on page 14.

Limit Current and I Monitor Transfer Functions	
PLD-5KCH	2 Amps / Volt
PLD-10KCH	4.6 Amps / Volt
PLD12.5KCH	5 Amps / Volt

Once Current Limit is detected, the output will turn off and the LIM I LED will illuminate red. The LIM I Status voltage will drop to ground and the LIM I LED will stay on until LD Enable is toggled off then on, and the error no longer exists.

- (3) **Set Operating Current.** Use the transfer function from step 2 to calculate the desired current. Monitor the voltage on the **I Monitor** pin (J2:4). With the **Output Adjust** trimpot fully counterclockwise (CCW), enable the output. Slowly adjust the **Output Adjust** trimpot CW until the desired voltage is measured on the **I Monitor** pin.
- (4) **Monitor the Photodiode (optional).** If the Photodiode is connected to the laser diode, check the voltage on the **P Monitor** pin (J2:3). The PD switch on top of the PLD will determine the output transfer voltage by the position of the switch:
 $Lo = 200 \mu A / V$ $Hi = 2 mA / V$
(15 - 500 μA range) (50 - 5000 μA range)
- (5) **Analog Input:** This input is designed for analog signals only and is not recommended for use with TTL signals. You can either input a DC voltage for remote current setpoint control or use this input to modulate the laser diode. The total setpoint voltage is the sum of the Analog Input voltage and the voltage introduced by the onboard trimpot. The input transfer function will depend on the PLD model in use.

Model	Transfer Function
PLD-5KCH	1 Amp / Volt
PLD-10KCH	2.3 Amps / Volt
PLD12.5KCH	2.5 Amps / Volt

CONSTANT POWER MODE

With the Output Disabled:

- (1) **Configure Mode Switch to CP.** [switch on top of PLD]
- (2) **Set Limit Current:** Monitor the **LMON** (J2:2) voltage and adjust the **LIM I** trimpot clockwise until the voltage on **LMON** corresponds to the desired level.

NOTE: The current limit circuit triggers slightly before the expected limit level. To fine tune the limit, add an offset voltage to the setting per the equation on page 14.

Limit Current and I Monitor Transfer Functions	
PLD-5KCH	2 Amp / Volt
PLD10KCH	4.6 Amp / Volt
PLD12.5KCH	5 Amps / Volt

Once Current Limit is detected, the output will turn off and the LIM I LED will illuminate red. The LIM I Status voltage will drop to ground and the LIM I LED will stay on until LD Enable is toggled off then on and the error no longer exists.

- (3) **Set the output power.**
 Determine the photodiode current from data provided with your laser diode. Monitor the voltage on the **P Monitor** pin (J2:3). Set the **PD Range Switch** for the appropriate photodiode current:
 $Lo = 15 - 500 \mu A$ $Hi = 50 - 5000 \mu A$

 With the **Output Adjust** trimpot fully CCW, enable the output. When the laser reaches threshold, the photodiode current changes abruptly and rises quickly. Adjust the **Output Adjust** trimpot slowly until the voltage on **PMON** (J2:3) corresponds to the desired photodiode current. Transfer functions for Low and High Photodiode mode are:
 $Lo = 200 \mu A / V$ $Hi = 2 mA / V$

For details on setting a custom photodiode range, see page 13.

- (4) **Analog Input:** This input is designed for analog signals only and is not recommended for use with TTL signals. You can either input a DC voltage for remote current setpoint control or use this input to modulate the laser diode. The total setpoint voltage is the sum of the Analog Input voltage and the voltage introduced by the onboard trimpot. The input transfer function is the same for all models and depends on the **PD RANGE** switch setting.
 $Lo = 100 \mu A / V$ $Hi = 1 mA / V$

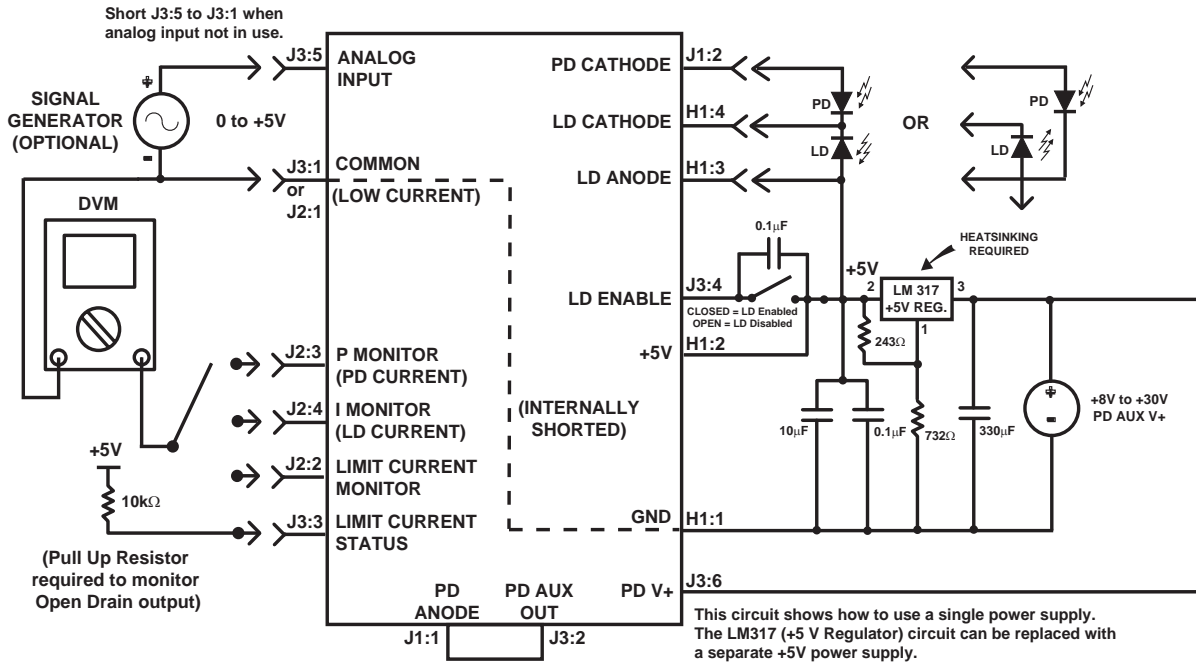

EXTERNAL ADJUSTMENTS

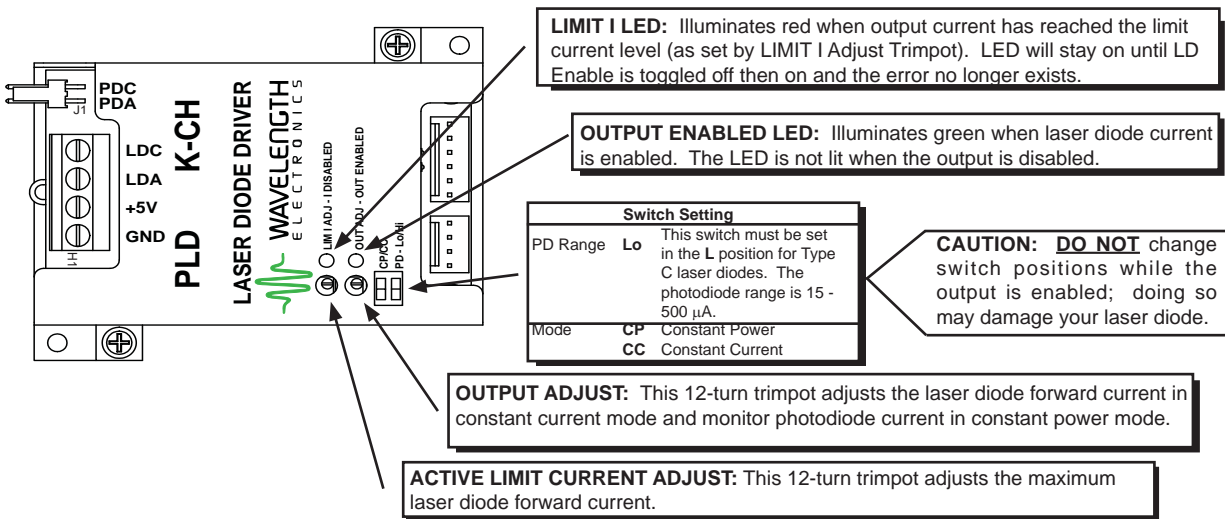

PLD5K-CH / PLD10K-CH / PLD12.5K-CH CHASSIS MOUNT LASER DIODE DRIVERS

CONSTANT CURRENT MODE

With the Output Disabled:

- (1) **Configure Mode Switch to CC.** [switch on top of PLD]
- (2) **Set Limit Current:** Monitor the voltage on the **LMON** pin (J2:2) and adjust **LIM I** trimpot clockwise (CW) until the voltage on the **LMON** pin corresponds to the desired level.

NOTE: The current limit circuit triggers slightly before the expected limit level. To fine tune the limit, add an offset voltage to the setting per the equation on page 14.

Limit Current and I Monitor Transfer Functions	
PLD-5KCH	2 Amps / Volt
PLD-10KCH	4.6 Amps / Volt
PLD12.5KCH	5 Amps / Volt

Once Current Limit is detected, the output will turn off and the LIM I LED will illuminate red. The LIM I Status voltage will drop to ground and the LIM I LED will stay on until LD Enable is toggled off then on, and the error no longer exists.

- (3) **Set Operating Current.** Use the transfer function from step 2 to calculate the desired current. Monitor the voltage on the **IMON** pin (J2:4) . With the **Output Adjust** trimpot fully counterclockwise (CCW), enable the output. Slowly adjust the **Output Adjust** trimpot CW until the desired voltage is measured on the **IMON** pin.
- (4) **Monitor the Photodiode (optional).** If the Photodiode is connected to the laser diode, monitor the **PMON** voltage (J2:3). The PD switch on top of the PLD should be set to **Lo** (High mode [Hi] is not available for type C configurations.):

$$Lo = 200 \mu A / V$$

- (5) **Analog Input:** This input is designed for analog signals only and is not recommended for use with TTL signals. You can either input a DC voltage for remote current setpoint control or use this input to modulate the laser diode. The total setpoint voltage is the sum of the Analog Input voltage and the voltage introduced by the onboard trimpot. The input transfer function will depend on the PLD model in use.

Model	Transfer Function
PLD-5KCH	1 Amp / Volt
PLD-10KCH	2.3 Amps / Volt
PLD12.5KCH	2.5 Amps / Volt

CONSTANT POWER MODE

With the Output Disabled:

- (1) **Configure Mode Switch to CP.** [switch on top of PLD]
- (2) **Set Limit Current:** Monitor the voltage on the **LMON** pin (J2:2) and adjust **LIM I** trimpot clockwise until the voltage on the **LMON** pin corresponds to the desired level.

NOTE: The current limit circuit triggers slightly before the expected limit level. To fine tune the limit, add an offset voltage to the setting per the equation on page 14.

Limit Current and I Monitor Transfer Functions	
PLD-5KCH	2 Amps / Volt
PLD-10KCH	4.6 Amps / Volt
PLD12.5KCH	5 Amps / Volt

Once Current Limit is detected, the output will turn off and the LIM I LED will illuminate red. The LIM I Status voltage will drop to ground and the LIM I LED will stay on until LD Enable is toggled off then on, and the error no longer exists.

- (3) **Set the output power.**
 Determine the photodiode current (I_m at operating current I_{OP}) from data provided with your laser diode. Monitor the voltage on **PMON** (J2:3). One photodiode range is available. Set the PD Range Switch to **Lo**:
 $Lo\ Range = 15 - 500 \mu A$
 With the Output Adjust trimpot fully CCW, enable the output. When the laser reaches threshold, the photodiode current changes abruptly and rises quickly. Adjust the **OUTPUT ADJUST** trimpot slowly until the voltage on **P Monitor** corresponds to the desired photodiode current. The transfer function is:
 $Lo = 200 \mu A / V$
 This can be adjusted with a resistor (R) connected between **PD Cathode** and **AUX V+**. The new range can be calculated with:
 $RANGE = 2.5 V / (R \parallel 5 k\Omega) \quad [A]$
 The new transfer function is:
 $TF = 1 / (R \parallel 5 k\Omega) \quad [A / V]$
 For example, a 500 Ω resistor converts RANGE to:
 $2.5 / (500 * 5000 / (500 + 5000)) = 5500\ mA\ max$
 and the transfer function to:
 $1 / (500 * 5000 / (500 + 5000)) = 2.2\ mA / V$
Please contact factory for details on choosing a custom photodiode range.

- (4) **Analog Input:** This input is designed for analog signals only and is not recommended for use with TTL signals. You can either input a DC voltage for remote current setpoint control or use this input to modulate the laser diode. The total setpoint voltage is the sum of the Analog Input voltage and the voltage introduced by the onboard trimpot. The input transfer function for all models is: **100 $\mu A / V$.**

Note that the transfer function will change if you change the photodiode RANGE. The new transfer function is $RANGE / 5 V$.

Remote Status LED circuit

A 332 Ω resistor is in series with the open drain output of the LIM I Status pin, so an external LED can be connected directly to the LIM I Status pin as shown.

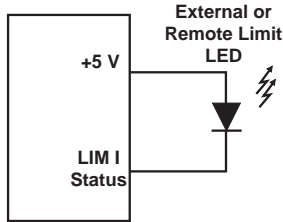

External Trimpot Circuit

Recommended circuit when an external trimpot is used to control the PLD output current.

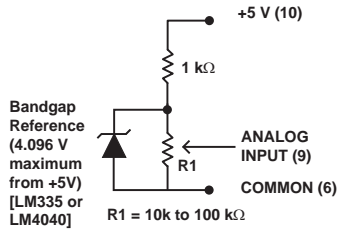

Monitor Calibration Circuit

A small offset may be present when measuring the P Monitor, I Monitor or LIM I Monitor voltage with respect to the actual output. Add this circuit to remove any offset.

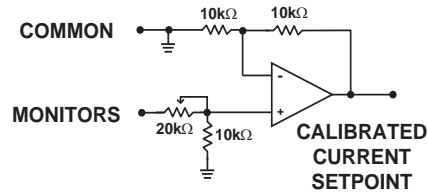

Change PD Range for TYPE A or B laser diodes

Put a resistor across the PD Anode and Common pins to modify the PD range of the PLD.

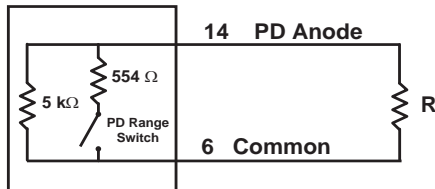

<p>PD Range = L</p> $\text{Range} = \frac{2.5 \text{ V} * 10^6}{R \parallel 5 \text{ k}\Omega} [\mu\text{A}]$ $\text{Transfer Function} = \frac{10^6}{R \parallel 5 \text{ k}\Omega} [\mu\text{A} / \text{V}]$ $R \parallel 5 \text{ k}\Omega = \frac{R * 5000}{R + 5000}$	<p>PD Range = H</p> $\text{Range} = \frac{2.5 \text{ V} * 10^6}{R \parallel 500 \Omega} [\mu\text{A}]$ $\text{Transfer Function} = \frac{10^6}{R \parallel 500 \Omega} [\mu\text{A} / \text{V}]$ $R \parallel 5 \text{ k}\Omega = \frac{R * 500}{R + 500}$
--	--

Laser Diode Protection when using a long cable

With a cable longer than two feet, add a Schottky diode across the laser diode.

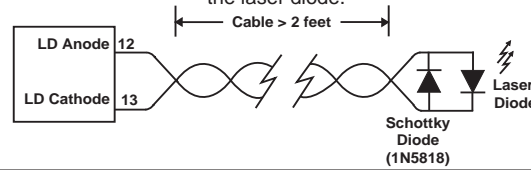

Filter the PLD Output If you don't need to modulate, you can reduce the noise by filtering the output current.

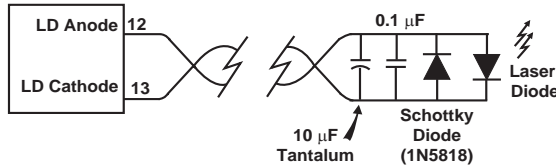

Change the Modulation Transfer Function

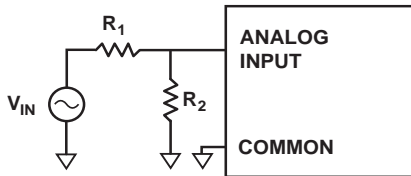

Keep R₁ and R₂ below 100 kΩ for maximum accuracy.

$$\text{New Transfer Function} = \frac{R_2}{R_2 + R_1} * \text{Old Transfer Function}$$

Example: R₁ = 9 kΩ
(for PLD10K-CH) R₂ = 1 kΩ

$$\text{New Transfer Function} = \frac{1}{1 + 9} * 2.3 \text{ A} / \text{V} = 230 \text{ mA} / \text{V}$$

Cable Lengths with Currents Greater than 5 A

The length and gauge of cable from the power supply or to the laser diode can impact performance. The resistance and inductance of the wire can reduce bandwidth or cause the voltage to the PLD to droop.

If +5 V is tied to LD Anode and I_{OUT} starts to oscillate as setpoint voltage approaches the limit setting (within 0.2 V), then your cables are too long. If you cannot shorten the cables, place a capacitor across +5 V and ground (~470 μF) to minimize droop. Always twist the wire pairs to eliminate reactance.

Parallel multiple PLDs for higher current outputs

Contact the Factory for more information on paralleling multiple units for higher current. Or see the following link to Application Note AN-LD06:

<http://www.teamwavelength.com/downloads/notes/an-lD06.pdf>

Fine Tuning Deep Modulation

If the analog modulation input is near the rail (>4.5 V), output current signal response may be insufficient. Performance may be improved by connecting a quality low-ESR 470 μF, 16 V electrolytic capacitor between the power terminals (+5 VDC and GND). This decoupling capacitor should be directly connected at terminal block H1.

Power Supply and Noise

The PLD-CH Laser Diode Drivers are designed for stable, low noise operation. The power supply you select will directly affect the noise performance of the driver. We recommend using a regulated, linear supply for optimum performance. Depending on your requirements, you may be able to use a switching power supply. Each case must be evaluated independently because a switching power supply will affect noise, transient, and stability performance. Wavelength Electronics offers an evaluation kit and power supplies for easy configuration and operation.

MODEL	MAX VOLTAGE	MAX CURRENT
PWRPAK-13A-5V	5 V	13 A
PWRPAK-11A-12V	12 V	11 A

Fine Tuning the Limit Current Setting

The limit current circuit contains a small amount of hysteresis, which causes the limit current to trip slightly before expected. If the PLD current is close to the limit setpoint this hysteresis may affect operation. To compensate, a small offset voltage can be added to the limit current setting:

$$HO = \text{Hysteresis Offset} = \frac{V_{+5V} - V_{IMON}}{25.9} \quad [V]$$

Example: PLD5K-CH with a current limit of 2.5 A operating from 5 V at Pin H1:2

$$HO = \frac{5 - 1.25}{25.9} = 0.14 \text{ V}$$

The transfer function for PLD5K-CH limit current monitor is 2 A / V as given on pages 10 and 12.

$$V_{LIM} = \frac{I_{LIM}}{2 \text{ A/V}} + HO = \frac{2.5}{2} \text{ V} + 0.14 \text{ V} = 1.39 \text{ V}$$

Grounding Schemes

CAUTION: If you plan to operate the PLD with any Wavelength temperature controller, you may need to use separate power supplies. If the TE cooler or thermistor is connected to the laser diode, you must either use two separate power supplies and let each float independently of the other or use a bipolar power supply.

CAUTION: IF LASER DIODE AND PHOTODIODE ARE ISOLATED (TYPE B LASER DIODE) Short the laser diode anode to the photodiode cathode. The PLD-CH Laser Diode Driver requires the photodiode to be connected to the laser diode. If no connection is made between the laser diode and the photodiode, then the PLD will not operate properly in constant power mode, and the power monitor will not read the proper photodiode current.

Some laser diode packages short either pin of the laser diode to the case, which may connect the pin to earth ground through system hardware. Special attention to the details of grounding will ensure safe operation. We offer the following definitions and options:

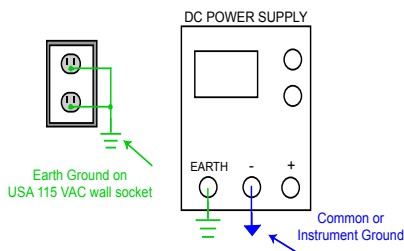

Unless Earth and Instrument Ground are connected via the power supply, Instrument Ground is floating with respect to Earth Ground

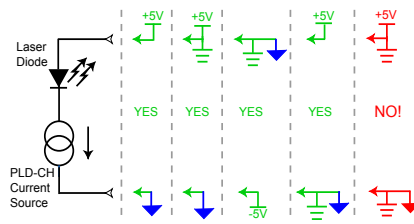

Example Grounding Configurations
(See page 11 for higher voltage operation.)

Power & Laser Diode Cable (WCB308)
-Connect to H1-

Order Separately



Standard lengths for high current wires are 24 inches. Longer leads will result in larger voltage drop, wire heating and decreased modulation bandwidth. Wires are twisted to optimize performance.

PIN	WIRE COLOR
1 - GND	Black
2 - +5V	Red
3 - LDA	White
4 - LDC	Blue

Strain relief of high current cables is strongly recommended to keep wires firmly attached to terminal block.

Photodiode Cable (WCB307)
-Connect to J1-

Included with PLDxxCH

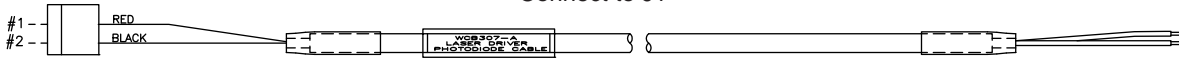

PIN	WIRE COLOR
1 - PDA	Red
2 - PDC	Black

Monitor Cable (WCB304)
-Connect to J2-

Included with PLDxxCH

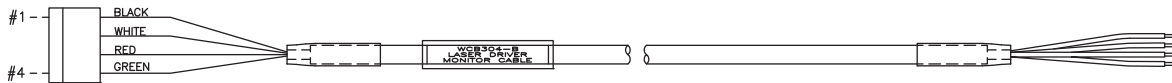

PIN	WIRE COLOR
1 - Common	Black
2 - LMON	White
3 - PMON	Red
4 - IMON	Green

I/O Cable (WCB305)
-Connect to J3-

Included with PLDxxCH

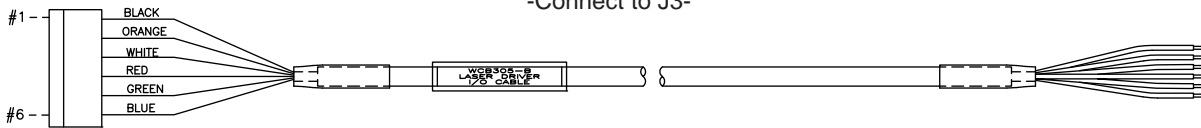

PIN	WIRE COLOR
1 - Common	Black
2 - PD Out	Orange
3 - LD Status	White
4 - LD Enable	Red
5 - Analog In	Green
6 - PDV	Blue

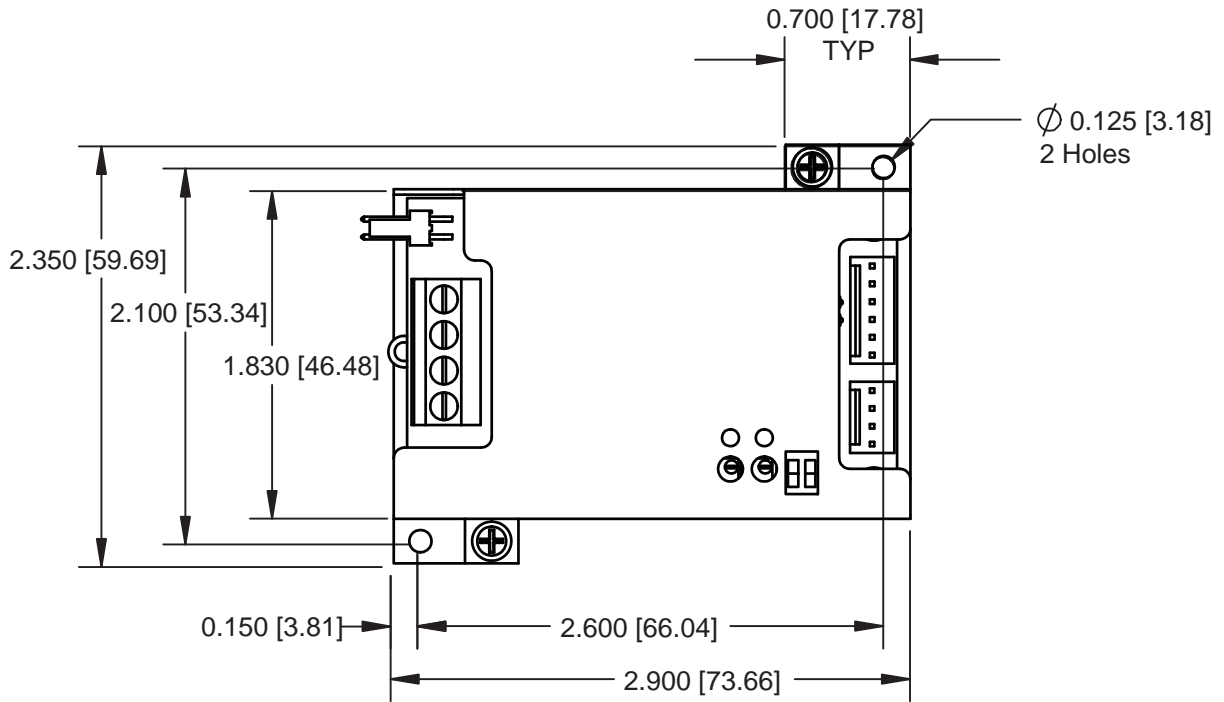

➔
Direction for Recommended Airflow

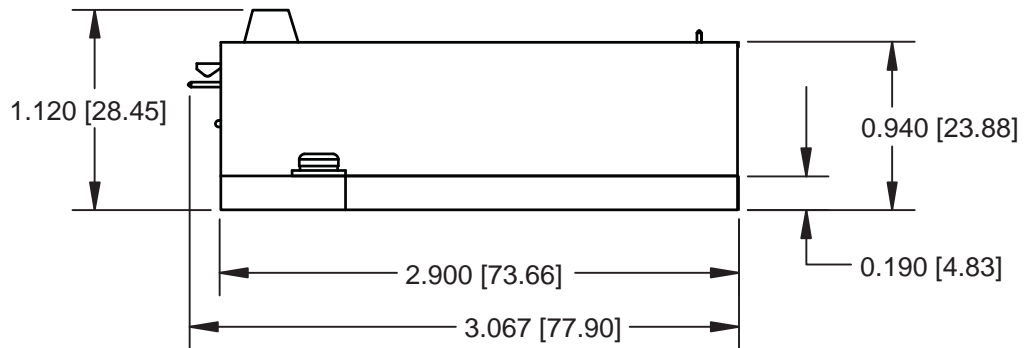

***All Tolerances are ±5%**

Dimensions are in Inches [mm]

CERTIFICATION:

Wavelength Electronics, Inc. (Wavelength) certifies that this product met its published specifications at the time of shipment. Wavelength further certifies that its calibration measurements are traceable to the United States National Institute of Standards and Technology, to the extent allowed by that organization's calibration facilities, and to the calibration facilities of other International Standards Organization members.

WARRANTY:

This Wavelength product is warranted against defects in materials and workmanship for a period of 90 days from date of shipment. During the warranty period, Wavelength will, at its option, either repair or replace products which prove to be defective.

WARRANTY SERVICE:

For warranty service or repair, this product must be returned to the factory. An RMA is required for products returned to Wavelength for warranty service. The Buyer shall prepay shipping charges to Wavelength and Wavelength shall pay shipping charges to return the product to the Buyer upon determination of defective materials or workmanship. However, the Buyer shall pay all shipping charges, duties, and taxes for products returned to Wavelength from another country.

LIMITATIONS OF WARRANTY:

The warranty shall not apply to defects resulting from improper use or misuse of the product or operation outside published specifications.

No other warranty is expressed or implied. Wavelength specifically disclaims the implied warranties of merchantability and fitness for a particular purpose.

EXCLUSIVE REMEDIES:

The remedies provided herein are the Buyer's sole and exclusive remedies. Wavelength shall not be liable for any direct, indirect, special, incidental, or consequential damages, whether based on contract, tort, or any other legal theory.

REVERSE ENGINEERING PROHIBITED:

Buyer, End-User, or Third-Party Reseller are expressly prohibited from reverse engineering, decompiling, or disassembling this product.



WAVELENGTH ELECTRONICS, INC.
 51 Evergreen Drive
 Bozeman, Montana, 59715
 web: www.teamWavelength.com
 phone: (406) 587-4910 Sales/Tech Support
 fax: (406) 587-4911
 e-mail: sales@teamWavelength.com

NOTICE:

The information contained in this document is subject to change without notice. Wavelength will not be liable for errors contained herein or for incidental or consequential damages in connection with the furnishing, performance, or use of this material. No part of this document may be photocopied, reproduced, or translated to another language without the prior written consent of Wavelength.

SAFETY:

There are no user serviceable parts inside this product. Return the product to Wavelength for service and repair to ensure that safety features are maintained.

LIFE SUPPORT POLICY:

As a general policy, Wavelength Electronics, Inc. does not recommend the use of any of its products in life support applications where the failure or malfunction of the Wavelength product can be reasonably expected to cause failure of the life support device or to significantly affect its safety or effectiveness. Wavelength will not knowingly sell its products for use in such applications unless it receives written assurances satisfactory to Wavelength that the risks of injury or damage have been minimized, the customer assumes all such risks, and there is no product liability for Wavelength. Examples of devices considered to be life support devices are neonatal oxygen analyzers, nerve stimulators (for any use), auto transfusion devices, blood pumps, defibrillators, arrhythmia detectors and alarms, pacemakers, hemodialysis systems, peritoneal dialysis systems, ventilators of all types, and infusion pumps as well as other devices designated as "critical" by the FDA. The above are representative examples only and are not intended to be conclusive or exclusive of any other life support device.

REVISION HISTORY		
REVISION	DATE	NOTES
REV. A	Jan-08	Initial release
REV. B	11-Nov-08	Monitor Accuracy data updated
REV. C	4-May-09	Added cable length note
REV. D	16-Aug-09	Added heatsink specification and deep modulation notes
REV. E	15-Jan-10	Updated for lower noise, higher bandwidth with release of PLD-CH Rev. C
REV. F	31-Dec-10	Added 12.5 A model
REV. G	20-Apr-11	Updated limit fine tuning
REV. H	12-Sep-11	Corrected ANALOG IN pin description
REV. I	13-Oct-11	Corrected High Compliance Voltage diagram

PLD5K-CH / PLD10K-CH / PLD12.5K-CH CHASSIS MOUNT LASER DIODE DRIVERS